



KICE DS SERIES II SCALES



OPERATOR'S MANUAL

TABLE OF CONTENTS

THE PURPOSE OF THIS MANUAL	3
OVERVIEW	3
PLANT REQUIREMENTS	4
SCALE CAPACITY	4
INSTALLATION	4
SAFETY	5
OPERATOR INTERFACE	7
QUICK START	9
GENERAL SETUP	11
SCALE ALARMS	15
ADVANCED SETTINGS	16
DIGITAL I/O INTERFACE	30
ETHERNET STATUS AND COMMAND WORDS	31
FACTORY DEFAULT SETTINGS	34
KICE SCALING SYSTEM APPENDIX/QUICK REFERENCE	35
PARTS LIST	36
TROUBLESHOOTING	40
GLOSSARY OF TERMS	45
APPENDIX	46

THE PURPOSE OF THIS MANUAL

The purpose of this manual is to provide information so an operator can educate themselves on the Kice scale operation, and to serve as a reference for troubleshooting potential problems.

A general overview is given in the function summary section which explains the Kice scale system's capabilities. A quick start section lists the steps necessary to begin using the scale. Operating instructions are located in the starting the scale section which describes how to navigate through the screens to make changes to settings. The scheduled maintenance section provides a guideline for routine maintenance to avoid unscheduled downtime, and a parts list is included to allow easy communication with Kice salesmen when ordering replacement parts. Incorporated into the parts list, are photos of each part to eliminate unnecessary confusion. The troubleshooting section includes possible problems and solutions so challenges can be quickly resolved. A glossary with brief definitions is also given to ensure that nomenclature does not become a source of uncertainty. Exploded views, electrical schematics, and pneumatic diagrams are also included for clarification.

OVERVIEW

One of the features that set the Kice Scaling System apart from any other scaling system, is its design using off the shelf Allen Bradley components readily available in North America.

The Kice Scaling System, featuring Kice Automation, is designed using Allen Bradley's CompactLogix controller, a highly functional industrial processor that provides an easy-to-use, modular, and flexible solution across a wide range of applications. This resides in an UL approved control enclosure located on the machine for ease of access.

To effectively monitor and control machine parameters, Kice Automation is using Allen-Bradley's PanelView 300 Micro as the Operator Interface (OI). This Liquid Crystal Display (LCD) with electronic buttons makes it easy to monitor and modify parameters.



PLANT REQUIREMENTS

115 VAC, 60 Hz, 10 Amp – This is used to supply power to the PLC, the solenoids, and the PanelView display. An inline surge suppressor or power conditioner is recommended.

80 psi clean, dry, plant air minimum – The dump valves are air actuated and performance can suffer as a result of low plant air pressure. Conversely the pressure should be regulated to no more than 100 psi.

Connectivity – The Kice scale can be operated as a stand alone unit or can be connected to a plant computer or PLC to be controlled remotely. Connecting to a plant computer or PLC can be accomplished with either an Ethernet connection or hardwired digital inputs and outputs. Each scale includes an Ethernet port and IO Terminals.

SCALE CAPACITY

Kice offers several different sizes of scales to accommodate most applications and flow rates. The capacities of the Kice lineup are listed below.

DS24-500 Series II

Volumetric flow rate: 500 cubic feet per hour
Weigh chamber volume: 2.77 cubic feet
Weight per cycle: max – 166 pounds
Density: max – 60 pounds/cubic foot

DS24-1000 Series II

Volumetric flow rate: 1000 cubic feet per hour
Weigh chamber volume: 5.79 cubic feet
Weight per cycle: max – 347 pounds
Density: max – 60 pounds/cubic foot

DS24-1500 Series II

Volumetric flow rate: 1500 cubic feet per hour
Weigh chamber volume: 8.31 cubic feet
Weight per cycle: max – 499 pounds
Density: max – 60 pounds/cubic foot

DS24-2000 Series II

Volumetric flow rate: 2000 cubic feet per hour
Weigh chamber volume: 11.21 cubic feet
Weight per cycle: max – 673 pounds
Density: max – 60 pounds/cubic foot

INSTALLATION

1. Lifting the scale into position should be done using the provided lifting loops at the top of the scale.
2. The surface that the scale will be installed on should be level and rigid – preferably on concrete.
3. The scale should be secured to the floor using the precut holes in the pads at the bottom of each leg.
4. The scale must be grounded to earth ground.

SAFETY

Kice recommends following OSHA and state safety laws to provide a safe working environment for operators, electricians, and maintenance personnel. Understanding electrical principles is important, when in doubt about a procedure ask your supervisor. Failure to follow proper safety guidelines can result in injury or death.

LOCK OUT / TAG OUT

Electrical power must be isolated when inspecting, servicing, or repairing the Kice scale system. To ensure the safety of personnel while repairs are being made, the equipment must be locked out and tagged out.

- Personnel should consult **OSHA Standard 29CFR1910.147** for industry standards on lockout / tagout.

There are two main potential hazards intrinsic to the scale. These are pinching by the dump valves, which are actuated by air, and electric shock. To lock these out see the list below.

LOCKOUT LIST:

- Air – A vented ball valve installed on the air filter inlet provides an isolation point for each scale, this valve may be used to isolate individual scales and drain compressed air from the lines.
- Electrical – The electrical power may be isolated using a breaker switch inside the control panel. Note: This breaker will only cut the power to equipment installed on the scale.



HAZARD LEVELS

The following definitions for identifying hazard levels are:



Danger (red) – Danger is used to indicate the presence of a hazard which **WILL** cause **SEVERE** personal injury, death, or substantial property damage if the warning is ignored.



Warning (orange) – Warning is used to indicate the presence of a hazard which **CAN** cause **SEVERE** personal injury, death, or substantial property damage if the warning is ignored.



Caution (yellow) – Caution is used to indicate the presence of a hazard which **WILL** or **CAN** cause **MINOR** personal injury or property damage if the warning is ignored.







Danger (yellow) – Disconnect main power before opening or servicing. It **WILL** cause **SEVERE** personal injury, death, or substantial property damage if the warning is ignored.

Safety decals on the scale should not be removed, covered, painted, or otherwise become illegible. If this occurs, the decals should be replaced immediately. Contact our customer service department for replacements.

1. Do not attempt to install, connect power, operate or service your new scale without proper instruction and thorough training in its use by your employer.
2. Do not attempt to work on, clean, service, open or remove any protective cover, guard, gate, or maintenance panel until the POWER and AIR has been turned off and LOCKED OUT.
3. Do not manually override or electronically bypass any protective device.
4. Do not connect power or operate the scale unless all covers, guards, grates, and maintenance panels are in place and securely fastened.
5. Never place any part of your body under or near rotating members or moving parts of the scale.
6. Many scales are wired to start automatically or from remote locations. Keep clear of all moving parts on industrial equipment at all times.
7. The air supply line to the filter must be equipped with a properly functioning padlockable valve.
8. It is the owner and employer's responsibility to adequately train the employee – operator in the proper and safe use of the scale. Written safety programs and formal instructions are essential. All new employees must be made aware of company policies and operating rules, especially established safety and health procedures. Refresher training of experienced employees in the potential hazards of the job is important. Up to date training records must be maintained at the job site for OSHA compliance.
9. Special attention must be devoted to outside contractors engaged to enter and perform work on the Kice Scale System or in the work place. Special care must be exercised to insure all such personnel are fully informed of the potential hazards and follow plant rules – with special emphasis on explosion proof electrical tools and cutting or welding in unsafe environments.
10. Keep the work place free of dirt and dust at all times. Do not attempt to work on slippery or unsafe ladders or work platforms when maintenance or repair work is being performed on the scales.
11. Do not climb on ladders or work on platforms unless maximum load rating is posted. Do not exceed maximum load ratings when installing or servicing scales.
12. Operate safely at all times. Use personal protective equipment when and where appropriate such as hard hats, helmets, gloves, ear plugs, and eye protection devices. Keep personal protective equipment in good repair and convenient to the operator.
13. Never stand under any kind of hoist or lifting mechanism, whether or not it is in operation. Never stand under or near a scale when it is being lifted.
14. All scale lifting devices must be inspected by qualified personnel before each use. Never use lifting device to transport equipment. Never use a lifting device that is damaged, deteriorated, or in any way in need of repair.
15. All protective covers, guards, grates, maintenance panels, switches, and warning decals must be kept in place and in good repair. Any equipment with damaged, malfunctioning, defective, or missing protective devices must be taken out of service until protective devices can be repaired or replaced.
16. Any equipment which is used in the processing of explosive materials in hazardous environments requires an evaluation on the part of the user and operator of equipment monitoring devices, dust control, explosion proof venting, and electrical enclosures. Do not use your equipment in hazardous environments unless it has been properly equipped for the hazard.
17. It is ultimately the operator's responsibility to implement the above listed precautions and insure proper use of the equipment, maintenance, and lubrication. Keep these instructions and list of warnings with your machine at all times.

OPERATOR INTERFACE

PICTURE	DESCRIPTION	USE
	Left and Right Buttons	Navigate menus and select numerical digits
	Up and Down Button	Change numerical values
	Enter Button	Save Parameters
	F1 Through F4 Button	Select Screen Parameters

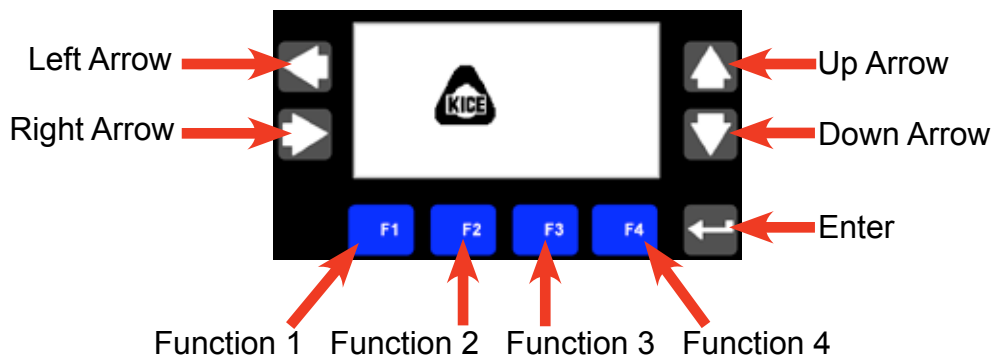

OPERATOR INTERFACE CONTINUED

PARAMETER ADJUST SCREEN

The screen on the right is the Parameter Adjust screen. This screen acts as the interface between the operator and the processor's parameters.

To change a parameter, depress the key associated with the parameter you would like to modify. The PanelView™ will immediately display the Parameter Adjust screen.

1. Use the left and right buttons to navigate through numerical digits.
2. Use the up and down buttons to change numerical values.
3. Press enter to save the new value and go back to the previous screen.
4. F1 takes you back to the previous screen without saving.



SCREEN SAVER

After a period of inactivity of the Operator Interface, a floating Kice logo is displayed as a screen saver. Press any button to return to the last active screen.



QUICK START

SCALE SETUP

1. Please verify the following:
 - a. The scale is firmly in place.
 - b. The scale has been grounded to earth ground.
 - c. Spouting connections have been made.
 - d. Remove 6 orange shipping brackets for the load cells.
 - e. Tighten large load cell bolts to 65lb-ft (2 in the center of each load cell) that may have been loosened to protect the load cell during shipping.

(2) NEUTRAL (N101)
(2) POWER (X101)

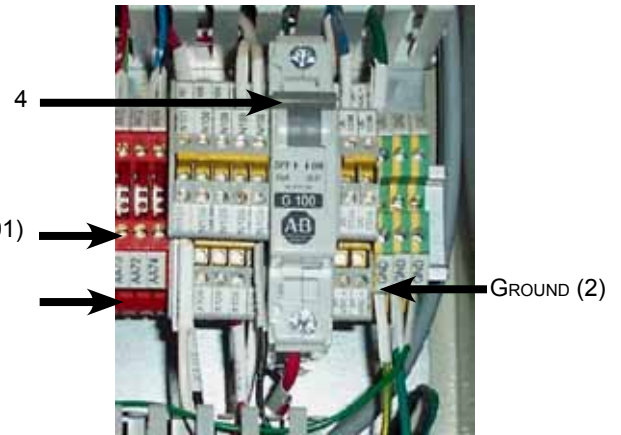

2. Supply 115 VAC, 60 Hz, 10 Amp to scale control panel.
3. Connect plant air to the scale air filter inlet, 80 psi minimum.
4. Power up the control panel breaker. The PanelView's Main Menu appears when the machine is first powered up.



BASIC SETUP MENU

The Basic Setup menu is used to select the Operating Mode of the scale, select display units and clear Scale Accumulation Total.

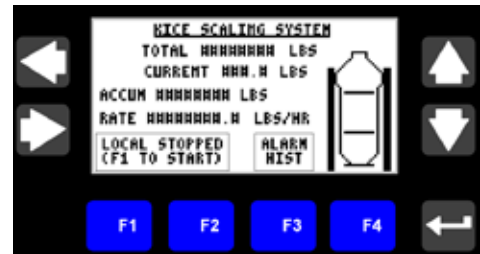

1. Advance to the Basic Setup Menu by pressing the Right Arrow.
2. Press F1 to Select the Mode. (Repeatedly pressing F1, will scroll through the modes)
 - Bypass: Inlet & Discharge gates are always open, scale is now bypassed.
 - Local Mode: Scale start/stop is controlled at Operator Interface.
 - Remote Mode: Scale start/stop is controlled by external digital input or Ethernet commands.
3. Press F2 to select the desired display Units. (Repeatedly pressing F2 will scroll through the available Units: lbs, cwt, metric tons (mt), bu or kg).
4. Press F3 to clear the Scale Accumulated Total (if needed).
5. Return to the Main Menu by pressing the Left Arrow.

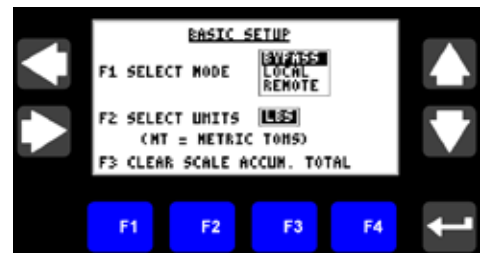

The Kice Scaling System is now ready to run. From the Main menu, clear any active alarms by pressing F4. Check the scale's status box, directly above the F1 and F2 buttons. If in Local Mode, Press F1 to Start the scale. If in Remote Mode, the Remote Start/Stop signal must be present before the scale will start cycling. The scale has been fully tested and calibrated at Kice Industries. However, it is recommended that the scale be re-calibrated after installation is complete. Refer to the Advanced Settings section for calibration instructions.

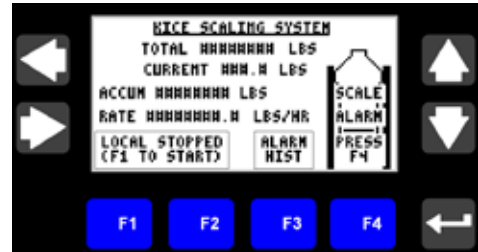

OR

BATCH MENU SETUP

If the Batching feature of the Kice Scaling System is desired, enter the desired Batch Target, in the indicated units (lbs, cwt, metric tons (mt), bu or kg). Entering a Batch Target of zero will disable the Batching feature of the Kice Scaling System.

1. Advance to the Basic Setup Menu by pressing the Right Arrow.
2. Advance to the Batch Setup Menu by pressing the Right Arrow.
3. Set the Batch Target (in indicated units)
 - a. Press F1 to select the Batch Target numeric entry.
 - b. Press the left/right arrow to select a numerical digit to be changed.
 - c. Press the up/down arrow to change numerical values.
 - d. Repeat b and c as necessary.
 - e. Press enter to save the new value or press esc to abort entry.

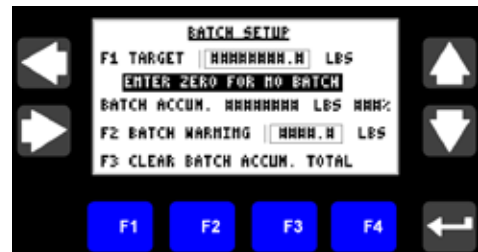
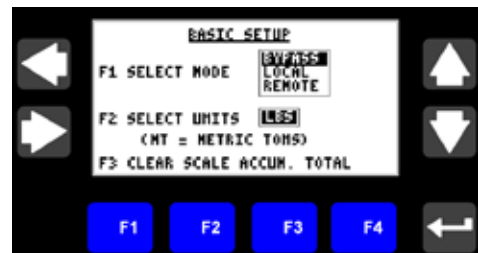

A "Batch Warning" set point can be configured to indicate when the Batch is nearing completion. The "Batch Warning" value is an amount remaining in the Batch when the "Batch Warning" status (digital output and Ethernet status bit) is turned ON.

4. Set the Batch Warning (in indicated units)
 - a. Press F2 to select the Batch Warning numeric entry.
 - b. Press the left/right arrow to select a numerical digit to be changed.
 - c. Press the up/down arrow to change numerical values.
 - d. Repeat b and c as necessary.
 - e. Press enter to save the new value or press esc to abort entry.
5. Clearing the Batch Accumulated Total
 - a. Press F3 to clear the Batch Accumulated Total (if needed).
 - b. Advance to the Main Menu by pressing the Left Arrow.



GENERAL SETUP

MAIN MENU

The default OI screen or main menu contains a graphical status of the scale and the most commonly monitored parameters.

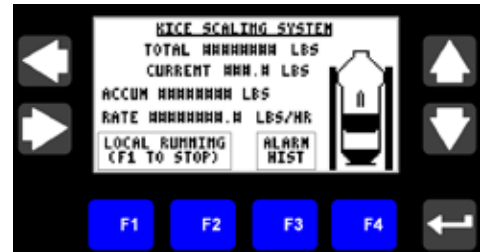

DISPLAYS

- This graphic shows both the Inlet and Discharge gates open.
- This graphic shows both the Inlet and Discharge gates closed.
- This graphic shows the Inlet gate open, Discharge gate closed and product in the weigh hopper.
- This graphic shows the Inlet gate closed, Discharge gate open and Lower Hopper at High Level.
- This graphic shows that a Scale Alarm is present.



Total: The Scale Total value is the “non-erasable” total accumulated weight of product through the scale and is incremented after every dump cycle. The value rolls-over at 99,999,999 lbs. The units (lbs, cwt, mt, bu or kg) are as indicated by the unit parameter, which can be selected on the Basic Setup menu.

Accum: This value displays the accumulated weight of product through the scale and is incremented after every dump cycle. This value is not displayed if the Batch mode is active. However, the value will continue to be updated after every dump cycle. The value is zeroed if the accumulated weight reaches 99,999,999 lbs or by pressing F3 on the Basic Setup menu. The units (lbs, cwt, mt, bu or kg) are as indicated by the unit parameter, which can be selected on the Basic Setup menu.

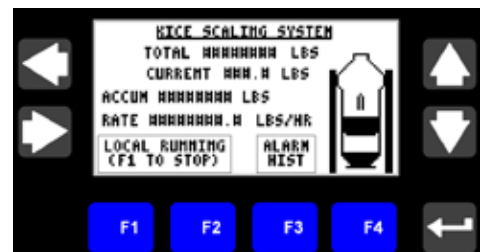

Batch: The Batch Accumulation value is displayed if the Batch mode is active. This value is the accumulated weight of product through the scale, while running a Batch and is incremented after every dump cycle. The Batch accumulated total is zeroed at the start of a new batch or by pressing F3 on the Batch Setup menu. The units (lbs, cwt, mt, bu or kg) are as indicated by the unit parameter, which can be selected on the Basic Setup menu.

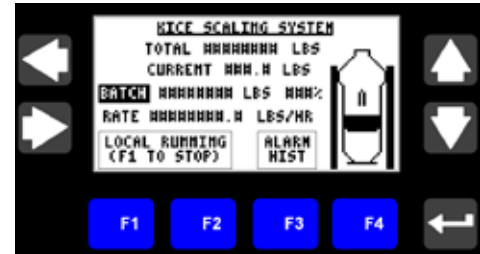

###%: This value displays the Batch Accumulated value as a percentage of the Batch Target. This value is only displayed when the Batch mode is active. When the Batch Accumulation value has reached the Batch Warning level, the Batch % value will “blink” as an indicator that the Batch is near completion.

Current: This value displays the actual weight, in lbs, of product in the scale.

Rate: This value displays the current flow rate of the scale. The value is updated continuously during scale operation. The units are displayed as “units”/hr where the units (lbs, cwt, mt, bu or kg) are as indicated by the unit parameter, which can be selected on the Basic Setup menu.

Alarm History: Press F3 to display the Alarm History menu. Press the Left Arrow to return to the Main menu.

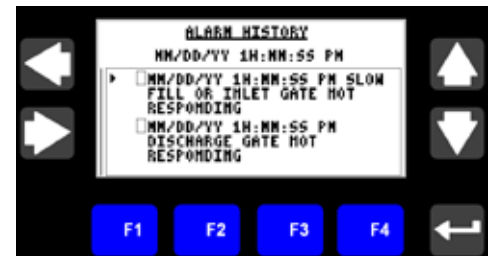







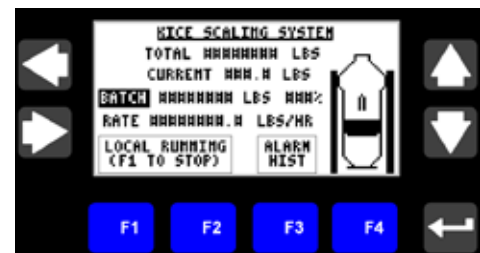

Alarm Reset: The Scale Alarm graphic is displayed when an alarm is active or unacknowledged. Press F4 to clear Alarms.



Scale Status: The current status of the scale is indicated in a text box directly above the F1 and F2 buttons. A list of the possible status messages and their meanings are shown on the following page.



-  Selected mode is Bypass, Inlet and Discharge gates are opened.
-  Selected mode is Remote, Remote Run command is "OFF", Inlet and Discharge gates are closed.
-  Selected mode is Remote, Remote Run command is "ON", and scale is cycling.
-  Selected mode is Local mode, Inlet and Discharge gates are closed, press F1 to Start cycling the scale.
-  Selected mode is Local mode, scale is cycling, press F1 to Stop the scale.
-  Batch is Finished, Inlet and Discharge gates are closed, press F2 to Restart.
-  Calibration has failed; scale is forced into Bypass mode until a successful calibration is achieved. Inlet and Discharge gates are opened.
-  Batch is finished, selected mode is Remote, Remote Run command is "ON", and scale is cycling.
-  Batch is finished, selected mode is Local, scale is cycling, press F1 to Stop cycling the scale.

Press the Right Arrow to navigate to the Batch Setup Menu.

BASIC SETUP MENU

The Kice Scaling System is designed for several modes of operation. The display units can be selected to lbs, cwt, mt, bu, or kg (Note: mt = metric tons).

1. Press F1 to select Mode of Operation
 - a. Bypass: The Scaling System is turned "OFF", the Inlet and Discharge gates are opened, allowing product to freely flow through the scale, with no weighing of product.
 - b. Local: The Scaling System can only be started or stopped at the Main menu of the Operator Interface.
 - c. Remote: The Scaling System can only be started or stopped by the Remote Run signals provided by an assigned digital input or Ethernet command.
2. Press F2, to select the displayed units (lbs, cwt, mt, bu or kg).
 - lbs = pounds
 - cwt = hundred-weights
 - mt = metric tons
 - bu = bushels
 - kg = kilograms
3. Press F3, to clear the Scale Accumulated Total (if needed).
4. Press the Right Arrow to advance to the Batch Setup menu or Press the Left Arrow to return to the Main menu.

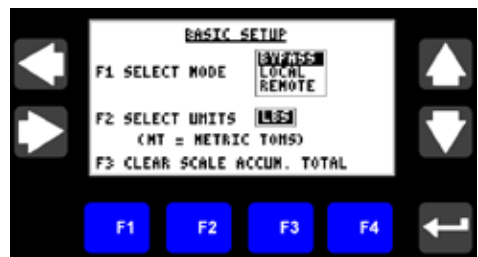

BATCH SETUP MENU

The Kice Scaling System can be configured to run in a Batch mode. For the Batch mode, enter the desired Batch Target, in selected units. Entering a Batch Target of 0, will disable the Batch Mode. If the Batch mode is selected, the scale will run until the Batch Accumulation value equals the Batch Target value. The Scale can be configured to “Stop” or “Alarm only” at the Completion of a Batch. This feature is selected in the End of Batch Setup menu, located in the advanced menus which require Login.

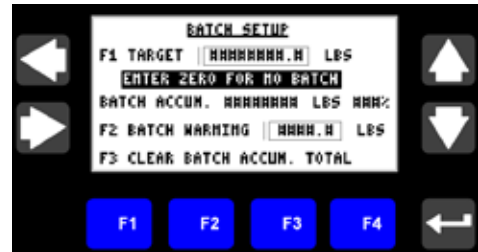

Batch Target: Press F1 to Enter the Batch Target, in the displayed units (lbs, cwt, mt, bu or kg). The display units can be selected on the Basic Setup menu. If the display units are changed, the Batch Target value will automatically update based on the current display units. For example, if the Batch Target was originally entered as 5000 lbs, then the display units were changed to cwt’s, the Batch Target would be recalculated and displayed as 50 cwts).

Batch Accum: The Batch Accumulation value is the accumulated weight of product through the scale, while running a Batch and is incremented after every dump cycle. The accumulated total is zeroed at the start of a new batch or by pressing F3 on the Batch Setup menu. The units (lbs, cwt, mt, bu or kg) are as indicated by the unit parameter, which can be selected on the Basic Setup menu.

Batch %: This value displays the Batch Accumulated value as a percentage of the Batch Target. This value is only displayed when the Batch mode is active. When the Batch Accumulation value has reached the Batch Warning level, the Batch % value will “blink” as an indicator that the Batch is near completion.

Batch Warning: Press F2 to Enter the Batch Warning setpoint, in the displayed units (lbs, cwt, mt, bu or kg). The display units can be selected on the Basic Setup menu. If the display units are changed, the Batch Target value will automatically update based on the current display units. The Batch Warning setpoint is the remaining value of the Batch during which the Batch Warning Output will be “ON”. For example, if the Batch Target is 5000 lbs and the Batch Warning set point is 500 lbs, the Batch Warning Output will turn “ON” when the Batch Accumulation is greater than 4500 lbs (Batch Target – Batch Warning set point).

Clear Batch Accumulated Total: Press F3 to clear the Batch Accumulated Total. When a new Batch is started, the Batch Accumulated Total will be cleared automatically.

Press the Right Arrow to advance to the Main menu or Press the Left Arrow to return to the Basic Setup menu.

SCALE ALARMS

When an alarm occurs, the OI will display the Alarm message and will trigger the Alarm Output according to the nature of the alarm. The Alarm Banner will only appear in the event of an alarm.

Alarm Acknowledge: Press F1 to Acknowledge only the Alarm displayed or Press F4 to Acknowledge all non-acknowledged alarms.

The different alarms that can be triggered are listed below.

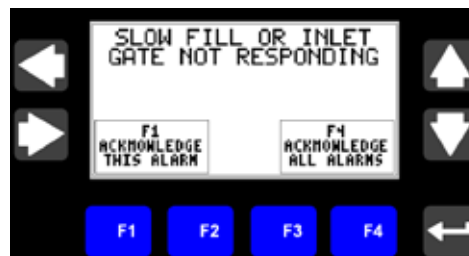

Alarm #	Alarm Description	Nature of Alarm	Action Taken by Processor
1	Slow Fill or Inlet Gate Not Responding	Critical	Alarm output is OFF
2	Discharge Gate Not Responding	Critical	Alarm output is OFF
3	Discharge Hopper High Level	Non Critical	Blinking Alarm Output
4	Discharge Gate Leakage Detected	Critical	Alarm output is OFF
5	Upper Hopper Level Sensor Has Been Disabled	Non Critical	Blinking Alarm Output
6	Lower Hopper Level Sensor Has Been Disabled	Non Critical	Blinking Alarm Output

Alarm Reset: The Scale Alarm graphic is displayed when an alarm is active or unacknowledged. Press F4 to clear Alarms.

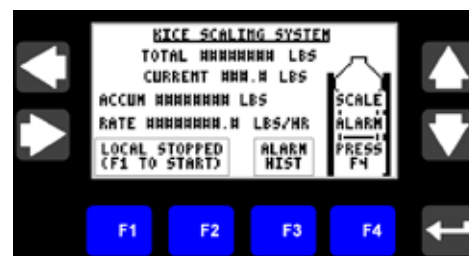

Alarm History: Press F3 to display the Alarm History menu. Press the Left Arrow to return to the Main menu.

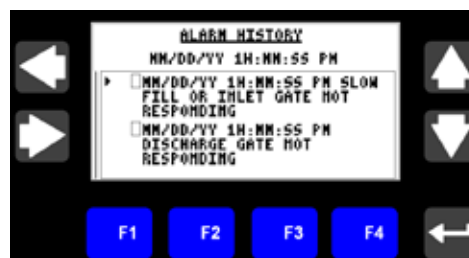

ADVANCED SETTINGS

BEFORE YOU BEGIN

This section can help you access the advanced settings for the Kice Scaling System. We base the procedure here on the assumption that you have an understanding of the Basic settings covered in the previous sections.

Because it is a start-up guide for experienced users, this section does not contain detailed explanations about the procedures. Kice Automation recommends reading all the instructions and manuals before attempting to run any equipment.

ELECTRICAL INTERCONNECTION

Please ensure that the Kice Scaling System has been wired according to the Kice Automation electrical schematic.

WHAT YOU NEED TO DO

This section covers:

1. Password Login Screen
2. Screen Select Menu
3. Upper Level Setup Menu
4. Lower Level Setup Menu
5. End of Batch Setup Menu
6. Scale Setup #1 Menu
7. Scale Setup #2 / Calibration Menu
8. Alarm Setup Menu
9. Input Check Menu
10. Gate Output Check Menu
11. Date Setup Menu
12. Time Setup Menu
13. Logging Out

1. PASSWORD LOGIN SCREEN

To access the advance settings of the Kice Scaling System, you must login.

Note: After a period of inactivity, you will be automatically logged out.

1. From the Main menu, press the Right Arrow button, to display the Basic Setup menu.
2. At the Basic Setup menu, press and hold F4 for 5 seconds. The Login menu will be displayed.
3. Press F1 (Login).
4. Enter the password: **5321**
 - a. Press the left/right arrow to select a numerical digit to be changed
 - b. Press the up/down arrow to change numerical values
 - c. Repeat a and c as necessary
 - d. Press enter to accept the password or press esc to abort entry
5. When correctly logged in, the displayed current user will be Maintenance.
6. Press the Up Arrow button to go to the Screen List Menu or Press the Left Arrow button to return to the Main menu.

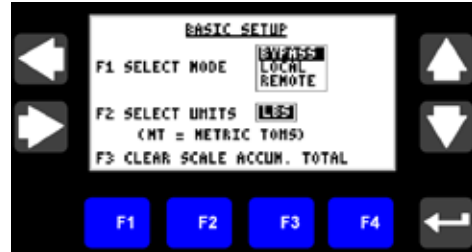

2. SCREEN SELECT MENU

Once Logged on, you have access to additional menus. A Screen Selection menu, is available to quickly navigate to the desired menu.

1. From the Main menu, press the Right Arrow button three times, to display the Screen Select menu.
2. Use the Up/Down Arrows to position the cursor at the Upper Level Setup menu.
3. Press Enter to accept the selection.



3. UPPER LEVEL SENSOR SETUP MENU

The Upper Level Sensor is an optional feature. Select "Disable" if the sensor is not installed or is not functioning correctly.

1. Press F1 to Enable/Disable the Upper Hopper Level feature.
2. If the Upper Hopper Level is disabled, Press F2 to select/de-select the Daily Notification that the sensor has been disabled.
3. Press the Right Arrow for the next setup screen or Press the Left Arrow for the previous screen or Press and Hold the Left Arrow to return to the Screen Select menu.



4. LOWER LEVEL SENSOR SETUP MENU

The Lower Level Sensor can be "Disabled" if the sensor is not installed or is not functioning correctly.

1. Press F1 to Enable/Disable the Lower Hopper Level feature.
2. If the Lower Hopper Level is disabled, Press F2 to select/de-select the Daily Notification that the sensor has been disabled.
3. Press the Right Arrow for the next setup screen or Press the Left Arrow for the previous screen or Press and Hold the Left Arrow to return to the Screen Select menu.



5. END OF BATCH SETUP MENU

Select the action of the scale when a Batch is completed.

1. Press F1 to Enable/Disable the feature to stop the scale at the completion of a batch.
2. Press the Right Arrow for the next setup screen or Press the Left Arrow for the previous screen or Press and Hold the Left Arrow to return to the Screen Select menu.

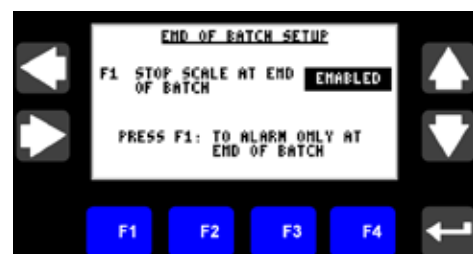

6. SCALE SETUP #1 MENU

The Scale Setup #1 menu is used to set Product Density, Dump size, Zero Flowrate Timeout and Flow Rate Averaging.

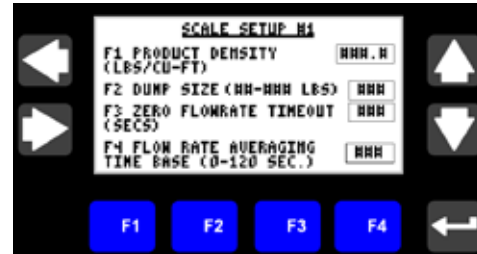

1. Set the Product Density (in lbs/cu-ft)
 - a. Press F1 to select the Product Density numeric entry
 - b. Press the left/right arrow to select a numerical digit to be changed
 - c. Press the up/down arrow to change numerical values
 - d. Repeat 3 and 4 as necessary
 - e. Press enter to save the new value
2. Set the Dump Size (in lbs)
 - a. Press F2 to select the Dump Size numeric entry
 - b. Repeat 1b. through 1e.
3. Set the Zero Flowrate Timeout (in seconds)



The displayed flowrate is updated after every dump cycle. If the dump cycle time exceeds the Timeout setting, the flowrate value is zeroed. This Timeout setting does not have any effect on the scale's operation, it only affects the displayed flowrate value.

- a. Press F3 to select the Zero Flowrate Timeout numeric entry
 - b. Repeat 1b. through 1e.
4. Set the Flow Rate Averaging Time Base – This is the length of time over which flow rate measurements are averaged. A longer time base will produce smoother transitions between flow rate variances.
 - a. Press F4 to select the Averaging Time Base numeric entry
 - b. Repeat 1b. through 1e.
5. Press the Right Arrow for the next setup screen or Press the Left Arrow for the previous screen or Press and Hold the Left Arrow to return to the Screen Select menu.

7. SCALE SETUP #2 MENU

The Scale Setup #2 menu is used to set the Weighing Averages, Vibration Immunity, perform Scale Calibration and Load Cell Diagnostics.

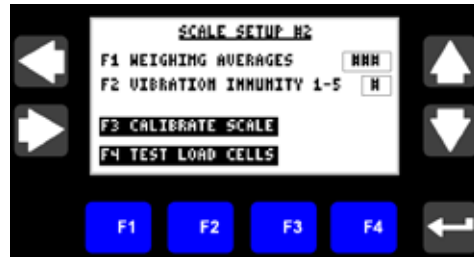

1. Set the Number of Averages.

Note: Kice Automation recommends setting the Number of Averages to 15.

- a. Press F1 to select the Weighing Averages numeric entry
- b. Press the left/right arrow to select a numerical digit to be changed
- c. Press the up/down arrow to change numerical values
- d. Repeat b and c as necessary
- e. Press enter to save the new value



2. Set the Vibration Immunity.

Note: Kice Automation recommends setting the Vibration Immunity to 3.

- a. Press F2 to select the Vibration Immunity numeric entry
- b. Repeat 2 through 5

3. Calibrating the scale

Note: Before calibrating make sure scale is completely empty. No test weight is required to calibrate this scale.

- a. Press F3 to select Calibrate Scale.

There are two different Calibration methods that are available. The "C2" Calibration method utilizes Hardy Instruments C2 electronic calibration which uses the pre-stored characteristics of the load cells for the calibration data. This method of calibration does not require the use of test weights and is recommended. An optional "Test Weight" method of calibration is also provided if desired.

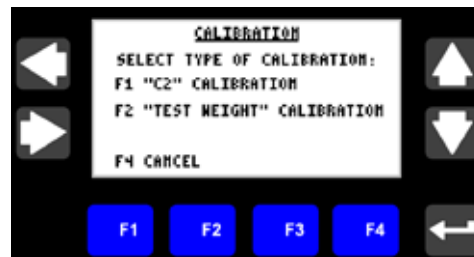

a. For “C2” Calibration

1. Press F1 to select “C2” Calibration
2. Pressing F4 – Cancel, will return to the previous screen
3. Scale Confirmation screen is displayed. Press F1-Yes to continue, Press F4-No to abort.



4. While the scale is calibrating, the message: “Scale is Calibrating, Please wait ...”, is displayed. (Calibration should take less than 20 seconds).



5. Successful Calibration Results

- a. Press F1 to Acknowledge.



6. Failed Calibration Results

- a. Record the displayed Status Code.
- b. Press F1 to Acknowledge.
- c. Check all Load Cell electrical connections.
- d. The scale will now be forced into Bypass mode, until a successful calibration is completed. Attempting to change to Local or Remote Modes will display the message: “Scale Calibration is Required. Bypass Mode is Invoked”. (Note: Cycling power to the scale controller will abort this requirement; however the scale’s accuracy could be unpredictable).



7. For “Test Weight” Calibration

- a. Press F2 to select “Test Weight” Calibration
- b. Pressing F4 – Cancel, will return to the previous screen



8. Ensure that all Test Weights are removed from scale. Press F1 to begin the “Zero” calibration portion. F4 – Cancel, will return to the previous screen



9. While the scale is calibrating Zero, the message: “Scale is Calibrating Zero, Please wait ...”, is displayed. (Calibration should take less than 20 seconds).



10. Successful Calibration Results

a. Press F1 to Acknowledge.



11. Place Test Weights on the scale.

a. Press F1 to enter Test Weight value.

b. Press F2 to begin the “span” calibration portion

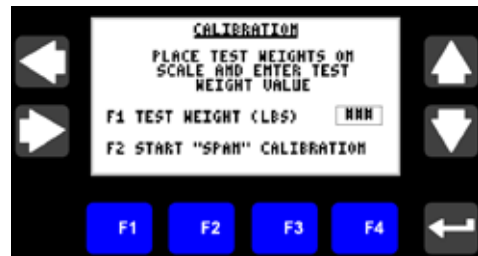

12. While the scale is calibrating the Span, the message: “Scale is Calibrating Span, Please wait ...”, is displayed. (Calibration should take less than 20 seconds).



13. Successful Calibration Results

a. Remove all Test Weights

b. Press F1 to Acknowledge.



14. Failed Calibration Results

- a. Record the displayed Status Code.
- b. Press F1 to Acknowledge.
- c. Check all Load Cell electrical connections.
- d. The scale will now be forced into Bypass mode, until a successful calibration is completed. Attempting to change to Local or Remote Modes will display the message: "Scale Calibration is Required. Bypass Mode is Invoked". (Note: Cycling power to the scale controller will abort this requirement; however the scale's accuracy could be unpredictable).

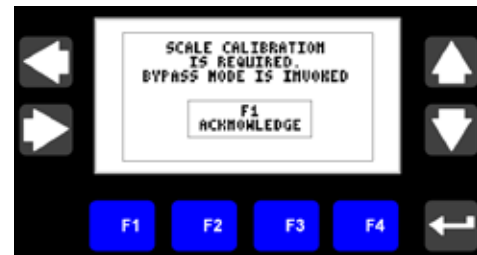

b. Test the Load Cells

- 1. Press F4 to select Test Load Cells.
- 2. Load Cell Test Confirmation screen is displayed. Press F1-Yes to continue, Press F4-No to abort.

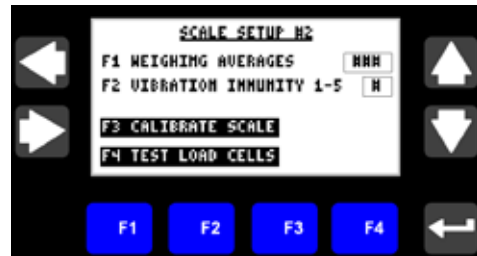

- 3. While the Load Cells are being tested, the "Testing Load Cells Please Wait...", is displayed. (Testing should take less than 20 seconds).



4. When the Load Cell tests are complete, the following test result screens will be displayed. Press F1 or F4 to navigate through the result screens. Contact either Hardy Instruments or Kice to assist in interpreting the results.

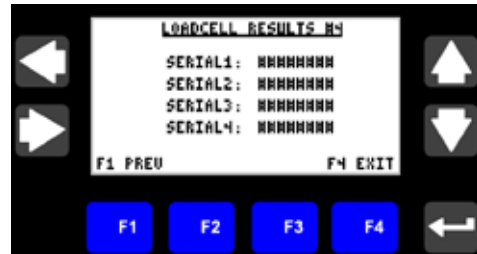
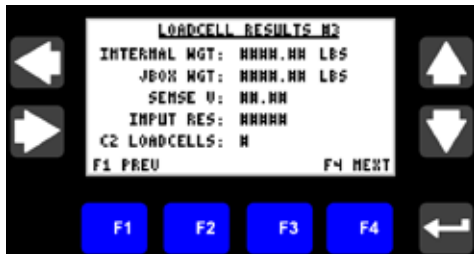
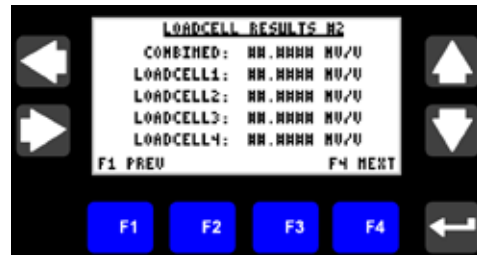
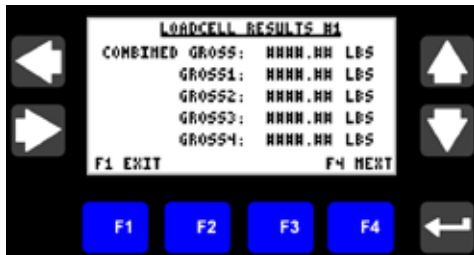

8. ALARM SETUP MENU

The Alarm setup menu is used to set the Slow Fill Alarm parameters and set the Lower Bin High Level Alarm Delay. (Note: Enter a 0 to disable the alarm).

1. Slow Fill Alarm Setpoint (lbs)

Note: Kice Automation recommends setting the Slow Fill Alarm Setpoint to 5 lbs.

- Press F1 to select the Setpoint (lbs) numeric entry
- Press the left/right arrow to select a numerical digit to be changed
- Press the up/down arrow to change numerical values
- Repeat b and c as necessary
- Press enter to save the new value

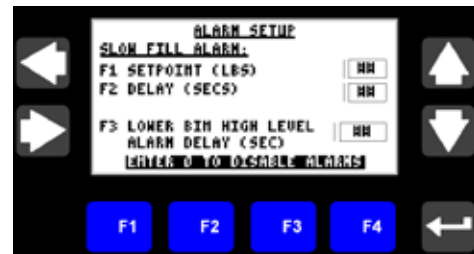

2. Slow Fill Alarm Delay (secs)

Note: Kice Automation recommends setting the Slow Fill Alarm Delay to 2 secs.

- a. Press F2 to select the Delay (secs) numeric entry
- b. Press the left/right arrow to select a numerical digit to be changed
- c. Press the up/down arrow to change numerical values
- d. Repeat b and c as necessary
- e. Press enter to save the new value

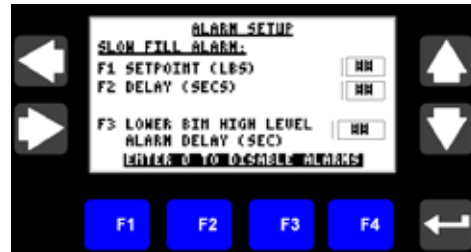

3. Lower Bin High Level Alarm Delay (secs)

Note: Kice Automation recommends setting the Level Alarm Delay to 5 secs.

- a. Press F3 to select the Lower Bin High Level Alarm Delay (secs) numeric entry
- b. Press the left/right arrow to select a numerical digit to be changed
- c. Press the up/down arrow to change numerical values
- d. Repeat b and c as necessary
- e. Press enter to save the new value
- f. Press the Right Arrow for the next setup screen or Press the Left Arrow for the previous screen or Press and Hold the Left Arrow to return to the Screen Select menu.

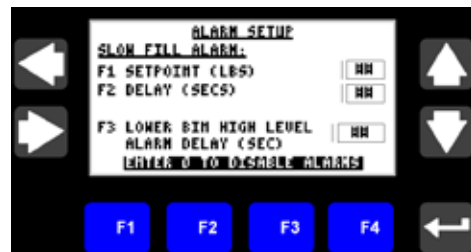

9. INPUT CHECK

The Input Check menu is used to verify the Kice Scaling Control System Inputs.

- The status (covered/uncovered) of the Upper Level Sensor is displayed.
- The status (covered/uncovered) of the Lower Level Sensor is displayed.
- The status (on/off) of the Remote Start signal is displayed. (Note: The Remote Start signal can come from either the hardwired digital input or Ethernet command).
- The status (on/off) of the Remote Batch Reset is displayed. (Note: The Remote Batch Reset signal can come from either the hardwired digital input or Ethernet command).
- The status (online/offline) of the Ethernet Command Communications is displayed. (Note: An Online status indicates that Communication with the Plant PLC has been successfully established).
- Press the Right Arrow for the next setup screen or Press the Left Arrow for the previous screen or Press and Hold the Left Arrow to return to the Screen Select menu.



10. GATE OUTPUT CHECK

The Gate Output Check menu is used to verify the operation of the Inlet and Discharge gates.

Note: The Kice Scaling System must be in “Bypass” mode before checking the outputs.

The statuses of the gate outputs are displayed. An “ON” status indicates that the output is energized (gate closed). An “OFF” status indicates that the output is not energized (gate opened).

1. Press and Hold F1 to close the Inlet Gate.
2. Press and Hold F2 to close the Discharge Gate.
3. Press the Right Arrow for the next setup screen or Press the Left Arrow for the previous screen or Press and Hold the Left Arrow to return to the Screen Select menu.

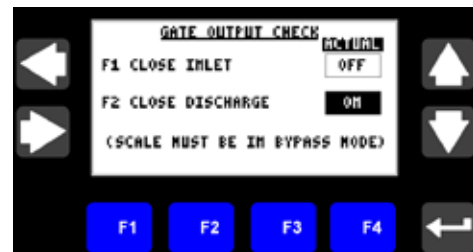

11. DATE SETUP MENU

The Date Setup Menu is used to check the current Date settings and Set a new Date for the OI and CompactLogix Controller.

Note: Ensure that the Year, Month and Day settings are correct prior to pressing F4.

1. Set the current Year

- Press F1 to select the Year numeric entry
- Press the left/right arrow to select a numerical digit to be changed
- Press the up/down arrow to change numerical values
- Repeat b and c as necessary
- Press enter to save the new value

2. Set the current Month

- Press F2 to select the Month numeric entry
- Press the left/right arrow to select a numerical digit to be changed
- Press the up/down arrow to change numerical values
- Repeat 3 and 4 as necessary
- Press enter to save the new value

3. Set the current Day

- Press F3 to select the Day numeric entry
- Press the left/right arrow to select a numerical digit to be changed
- Press the up/down arrow to change numerical values
- Repeat b and c as necessary
- Press enter to save the new value

4. Press F4-Set Date to update the Date settings.

- Press the Right Arrow for the next setup screen
or Press the Left Arrow for the previous screen
or Press and Hold the Left Arrow to return to the Screen Select menu.

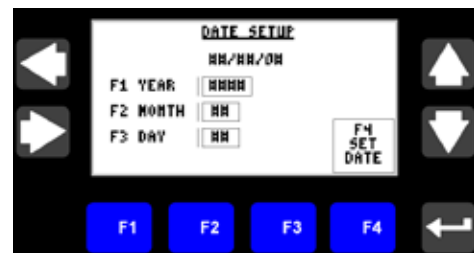
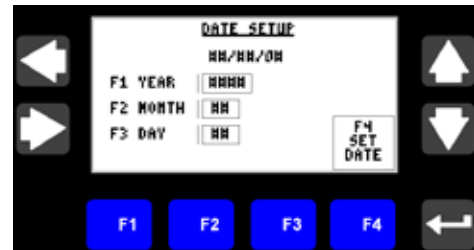

12. TIME SETUP MENU

The Time Setup Menu is used to check the current Time settings and Set a new Time for the OI and CompactLogix Controller.

Note: Ensure that the Hour, AM/PM, and Minute settings are correct prior to pressing F4.

1. Enter the current Hour
 - a. Press F1 to select the Hour numeric entry
 - b. Press the left/right arrow to select a numerical digit to be changed
 - c. Press the up/down arrow to change numerical values
 - d. Repeat 3 and 4 as necessary
 - e. Press enter to move to the next entry box
2. Press F2 to toggle the AM/PM setting
3. Enter the current Minute
 - a. Press F3 to select the Minute numeric entry
 - b. Press the left/right arrow to select a numerical digit to be changed
 - c. Press the up/down arrow to change numerical values
 - d. Repeat b and c as necessary
 - e. Press enter to move to the next entry box
4. Press F4-Set /Time to set the Time settings.
5. Press the Right Arrow to return to the Screen Select menu or Press the Left Arrow for the previous screen.



13. LOGGING OUT

It is recommended that you logout after you have finished with the Advanced menus. However, after a period of inactivity, you will be automatically logged out.

1. From the Screen Select menu, use the Up/Down Arrows to position the cursor at "Logout Screen".
2. Press Enter to accept the selection.



3. The Login/Logout menu is displayed. Press F4-Logout.



4. When successfully logged out, the following will be displayed: "Current User: Operator"
5. Press the Left Arrow to return to the Main menu.

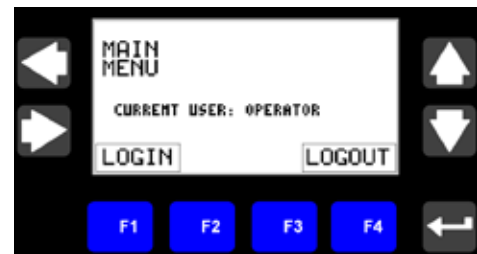

DIGITAL I/O INTERFACE

The Kice Scaling System has several preconfigured digital inputs and outputs that can be used to remotely control and monitor the Scaling System. Please ensure that the Kice Scaling System has been wired according to the Kice Automation electrical schematic. Below is a listing of the available inputs and outputs and their status indications.

- **Scale Digital Outputs:** The following is a list of available digital outputs that can be used to monitor the status of the Kice Scaling System. These status outputs are updated regardless of the Mode (Bypass, Local or Remote) that is selected.

Scale Digital Outputs		
I/O Terminal #	Description	Status Indication
DCAA24	BATCH STATUS OUTPUT	“ON” = Batch is Done “Blinking” = Batch Warning
DCAA28	SCALE RUNNING OUTPUT	“ON” = Scale is Running
DCAA32	SCALE ALARM OUTPUT	ON” = No Alarms “Blinking” = Non-Critical Alarm “OFF” = Critical Alarm

Note: “Blinking” output rate is 0.5 Hz (1.0 sec “ON”, 1.0 sec “OFF”, 1.0 “ON”, ... repeating)

- **Scale Digital Inputs:** The following is a list of available digital inputs that can be used to control the Kice Scaling System.

Scale Digital Inputs		
I/O Terminal #	Description	Command Indication
DCAA48	REMOTE START/STOP INPUT	ON” = Scale Run Command
DCAA50	REMOTE BATCH RESTART INPUT	“ON” = Restart Batch Command

- **Remote Start/Stop Input:** This input is used to remotely Start/Stop the scale. The Scale must be in “Remote” mode to use this command. The input must be held “ON” for the scale to run. Please ensure that all necessary downstream equipment is running prior to issuing a Run command.
- **Remote Batch Restart Input:** This input is used to remotely Restart a Batch once the Batch has completed. The BATCH STATUS OUTPUT can be monitored to determine when the Batch is Done. When the controller receives the Batch Restart Input, the Batch Accumulation value will be zeroed and another Batch will begin, when a Run command is received. Please ensure that this input is not held “ON” continuously.

ETHERNET STATUS AND COMMAND WORDS

The Kice Scaling System has been pre configured with a series of status and command addresses that can be used to remotely control and monitor the Scaling System. These addresses can be messaged from another PLC or HMI via an Ethernet network. These addresses were chosen to be compatible with (SLC, PLC5, CLX and CPLX processors). Below is a listing of the available status and command addresses and their indications.

Ethernet Status/Command Addresses			
Addresses	# of Words	Data Type	Description
F13:0 – F13:29	30	Floating Point	Scale Status Words
N14:0 – N14:2	3	Integer	Scale Status Words
F11:0 - F11:9	10	Floating Point	Scale Command Words
N12:0 – N12:1	2	Integer	Scale Command Words

SCALE STATUS WORDS – FLOATING POINTS	
Address	Description
F13:0	Scale Non-Erasable Total, lbs (value will roll over at 99,999,999 lbs)
F13:1	Scale Accumulation, lbs (clear value with bit N12:0/5, will roll over at 99,999,999 lbs)
F13:2	Batch Accumulation, lbs (clear value with bit N12:0/4, will roll over at 99,999,999 lbs)
F13:3	Scale Actual, lbs
F13:4	Scale Flow rate, lbs/hr
F13:5	Batch Setpoint, lbs
F13:6	< reserved >
F13:7	< reserved >
F13:8	< reserved >
F13:9	< reserved >
F13:10	< reserved >
F13:11	< reserved >

ETHERNET STATUS AND COMMAND WORDS

SCALE STATUS WORDS – FLOATING POINTS	
Address	Description
F13:12	< reserved >
F13:13	< reserved >
F13:14	Gross Weight, lbs
F13:15	Tare Weight, lbs
F13:16	Net Weight, lbs
F13:17	Dump Target Setpoint, lbs
F13:18	< reserved >
F13:19	< reserved >
F13:20	< reserved >
F13:20	< reserved >
F13:21	< reserved >
F13:22	< reserved >
F13:23	< reserved >
F13:24	< reserved >
F13:25	< reserved >
F13:26	< reserved >
F13:27	< reserved >
F13:28	< reserved >
F13:29	< reserved >

SCALE STATUS WORDS – INTEGERS / BITS	
Address	Description
N14:0	< reserved >
N14:1/0	Slow Fill Alarm
N14:1/1	Discharge Hopper Gate not Responding Alarm
N14:1/2	Discharge Hopper High Level Alarm
N14:1/3	Discharge Gate Leakage Detected Alarm
N14:1/4	Upper Hopper Level Sensor is Disabled Notification Alarm
N14:1/5	Lower Hopper Level Sensor is Disabled Notification Alarm
N14:1/6	< reserved >
N14:1/7	< reserved >
N14:1/8	< reserved >
N14:1/9	< reserved >
N14:1/10	< reserved >
N14:1/11	< reserved >
N14:1/12	< reserved >

ETHERNET STATUS AND COMMAND WORDS

SCALE STATUS WORDS – INTEGERS / BITS	
Address	Description
N14:1/13	< reserved >
N14:1/14	< reserved >
N14:1/15	< reserved >
N14:2/0	Scale is Bypassed
N14:2/1	Scale in Local Mode
N14:2/2	Scale in Remote Mode
N14:2/3	Scale is Running
N14:2/4	Batch Warning
N14:2/5	Batch is Done
N14:2/6	Scale Alarm (clear Alarms with bit N7:0/3)
N14:2/7	Upper Level Sensor is Covered
N14:2/8	Lower Level Sensor is Covered
N14:2/9	Inlet Gate Close Solenoid Valve is Energized
N14:2/10	Discharge Gate Closed Solenoid Valve is Energized
N14:2/11	Communication Heartbeat (when this bit is received, respond with bit N12:0/6)
N14:2/12	< reserved >
N14:2/13	< reserved >
N14:2/14	< reserved >
N14:2/15	< reserved >

SCALE COMMAND WORDS – FLOATING POINTS	
Address	Description
F11:0	Batch Target Setpoint, lbs (bit N12:0/0 must be “High” to update setpoint)
F11:1	Clock Year Setpoint (bit N12:0/7 must be “High” to update setpoint)
F11:2	Clock Month Setpoint (bit N12:0/7 must be “High” to update setpoint)
F11:3	Clock Day Setpoint (bit N12:0/7 must be “High” to update setpoint)
F11:4	Clock Hour Setpoint (bit N12:0/7 must be “High” to update setpoint)
F11:5	Clock Minute Setpoint (bit N12:0/7 must be “High” to update setpoint)
F11:6	< reserved >
F11:7	< reserved >
F11:8	< reserved >
F11:9	< reserved >

SCALE COMMAND WORDS – INTEGER (BITS)	
Address	Description
N12:0/0	Batch Target Setpoint Notify (this bit must be “High” to update F11:0)
N12:0/1	Scale Run Command (scale must be in Remote mode)
N12:0/2	Batch Restart (Batch must be done, see N14:2/5)
N12:0/3	Clear Alarms
N12:0/4	Clear Batch Accum Total (see address F13:2)
N12:0/5	Clear Scale Accum Total (see address F13:1)
N12:0/6	Communication Heartbeat (this bit must be “High” , when N14:2/11 is received)
N12:0/7	Clock Setpoint Notify (this bit must be “High” to update clock settings F11:1 – F11:5)
N12:0/8	< reserved >
N12:0/9	Remote Mode Bit (Sends Scale into Remote Mode)
N12:0/10	Bypass Mode Bit (Sends Scale into Bypass Mode)
N12:0/11	< reserved >
N12:0/12	< reserved >
N12:0/13	< reserved >
N12:0/14	< reserved >
N12:0/15	< reserved >
N12:1	< reserved >

Communication Heartbeat: The communication heartbeat status bit N14:2/11 and heartbeat command bit N12:0/6 are used to validate successful communication between the plant PLC and scale controller over an Ethernet network. This heartbeat must be in place at all times. If the scale controller does not receive the heartbeat for a period of time, the command words are not accepted. Below is an example of how the communication heartbeat bits N14:2/11 and N12:0/6 should be programmed in the plant PLC’s ladder logic.

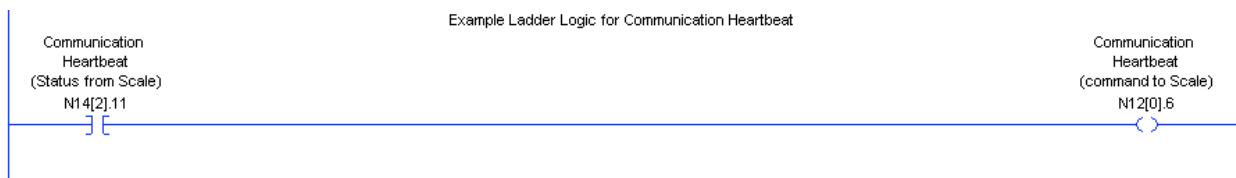

Communication Status Indicator: A

“Heartbeat” status indicator, located in the upper left corner of the main menu, will blink on/off; indicating that communication between the plant PLC and scale controller has been established. If communication has not been established, the “Heartbeat” status indicator will not be visible.

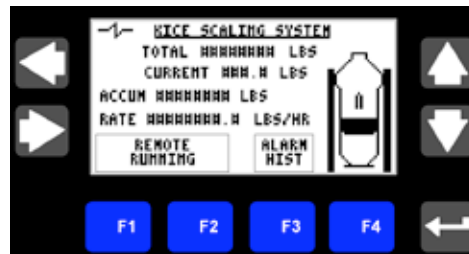

FACTORY DEFAULT SETTINGS

Parameter Description	Value
Weighting Averages	15
Vibration Immunity	3
Slow Fill Alarm Setpoint (lbs)	5
Slow Fill Alarm Delay (secs)	2
Lower Bin High Level Alarm (sec)	5

KICE SCALING SYSTEM APPENDIX/QUICK REFERENCE

Clear an Alarm

1. Press F1 to acknowledge the alarm
2. Use the Left Arrow button to navigate to the main menu
3. Press F4 to clear the alarm

Select Mode

1. Navigate to the Basic Setup menu
2. Press F1 to select the mode

Start a Batch

1. Navigate to the Batch Setup menu
2. Press F1 to select and adjust the Batch Target parameter
3. Navigate to the Main menu, Press F1 to Start the Scale

Clear Batch Accumulation

1. Navigate to the Batch Setup menu
2. Press F3 to clear the Batch Accumulation

Change displayed Units

1. Navigate to the Basic Setup menu
2. Press F2 to select the desired units







Clear Scale Accumulation

1. Navigate to the Basic Setup menu
2. Press F3 to clear the Scale Accumulation

PARTS LIST

Part	Inventory Number	Photo
Air Connector 90	10001259	
Air Connector Bulkhead	10001257	
Air Manifold	PSM5BX102NP	
Air Muffler	1001245	
Actuator Solenoid	B511BB553C	
Air Tee with 1 Threaded End	10001248	
Air Tubing	10001246	

PARTS LIST CONTINUED

<p>Air Connector Y</p>	<p>W368GC-6-6</p>	
<p>Dump Valve</p>	<p>SCL-224-2000</p>	
<p>Isolation Sleeve</p>	<p>IS24.25x6.5NYL</p>	
<p>Isolation Sleeve Clamp</p>	<p>5215K35</p>	
<p>Kinetrol Actuator</p>	<p>099-100</p>	
<p>Load Cell</p>	<p>HI LPRE 440-33C</p>	
<p>Male Connector 1/4" to 3/8" tube</p>	<p>1001247</p>	

PARTS LIST CONTINUED

Male Connector 3/8" to 3/8" tube	10001250	
Spring Pin	10000071	
Scale Body	SCL-224-2300 SCL-224-2310 SCL-224-2320 SCL-224-2330	
Solenoid Cable	U99-13430 TC8S 2-N653-5M	
Vent Sleeve	VS8.25x21PF12	
Top Valve Isolation Sleeve	IS5.25x1.75NYL	

PARTS LIST CONTINUED

Air Filter	2003N-IBI-DX	
Air Filter Element	100-12-DXE	
Plant Air Isolation Valve	10001344	
Load Cell Grommet	9307K49	 (shown next to Penny)

TROUBLESHOOTING

Problem	Cause	Solution	
Discharge gate leakage alarm	Air pressure to discharge valve too low	Check plant air pressure (>80 psi)	Air valve not fully open
		Air line kinked, broken, disconnected	
	Valve flap not turning with actuator	Spring pin between actuator and discharge gate shaft broken - replace pin page 43	Actuator coupler edges have rounded - replace coupler
Discharge gate not responding	Weight does not decrease within allotted time	Check discharge gate actuators	Vibration immunity may be too high-set to 3 or 4
Lower hopper level alarm	Discharge hopper level indicator is covered	Empty the discharge hopper	If the hopper is empty, the level indicator may need to be adjusted.
Product will not flow through the scale	Batch system is enabled and has met target	If the batch system is not desired, set the batch target to 0. See page 14	Restart batch page 14
	Discharge hopper level indicator is covered	Empty the discharge hopper	If the hopper is empty, the level indicator may need to be adjusted.
Scale displays unbelievable weights and will not recalibrate	Load cell is not sensing weigh chamber weight	Check for loose electrical connections page 54	Check for loose load cell bolts
Scale displays unbelievable weights	Load cells need to be calibrated	Calibrate load cells. See page 20	
Scale does not cycle or show weights with product flowing through the scale	Bypass mode is selected	Change to either remote or local mode. See page 13	
Slow fill alarm	Adequate weight was not added to the weigh chamber	Supply bin is empty	Conveyors feeding scale have been shut off
		Product is bridged above inlet hopper	

PARTS LIST			
	QTY	ITEM	PART #
A	1	TATTLE TALE SLEEVE	VS8.25x21PF12
B	1	24-500 TATTLE TALE ASM 24-1000 TATTLE TALE ASM 24-1500 TATTLE TALE ASM 24-2000 TATTLE TALE ASM	SCL-224-2260 SCL-224-2270 SCL-224-2280 SCL-224-2290
C	2	8" HOSE CLAMP	100124HB
D	1	AIR LOOP ISOLATION SLEEVE	IS5.25X1.75NYL
E	1	24-500 AIR LOOP BRANCH 24-1000 AIR LOOP BRANCH 24-1500 AIR LOOP BRANCH 24-2000 AIR LOOP BRANCH	SCL-224-2230 SCL-224-2230 SCL-224-2240 SCL-224-2250
F	3	8" 2 BOLT MORRIS COUPLING	82M8-2
G	2	5" HOSE CLAMP	62076ENB
H	1	24-500 INLET SURGE HOPPER 24-1000 INLET SURGE HOPPER 24-1500 INLET SURGE HOPPER 24-2000 INLET SURGE HOPPER	SCL-224-2380 SCL-224-2380 SCL-224-2390 SCL-224-2400
I	4	DS24 VALVE GASKET	GSKTSCL-920-3020

PARTS LIST			
	QTY	ITEM	PART #
J	2	DS24 FLAP VALVE	SCL-224-2000
K	1	TOP VALVE SHROUD	SCL-224-2030
L	1	INLET HOPPER SUPPORT DECK	SCL-224-2090
M	1	CONTROL PANEL	SCL-224-2410
N	1	UPPER SUPPORT DECK	SCL-224-2070
O	1	PLANT AIR ISOLATION VALVE	VVP500P-6
P	1	MALE HEX NIPPLE	6-6 MHLN-B-4.0
Q	1	AIR FILTER	2003N-1B1-DX
R	1	LOWER SUPPORT DECK	SCL-224-2050
S	2	SOLENOID CABLE	E492N50012C4L
T	2	SOLENOID	B511BB553C
U	2	MUFFLER/FLOW CONTROLLER	045060060
V	1	SOLENOID MANIFOLD	PSM5BXN02NP
W	3	LOAD CELL	HILPRE440-33C
X	6	SHIPPING BRACKET	SCL-224-3050

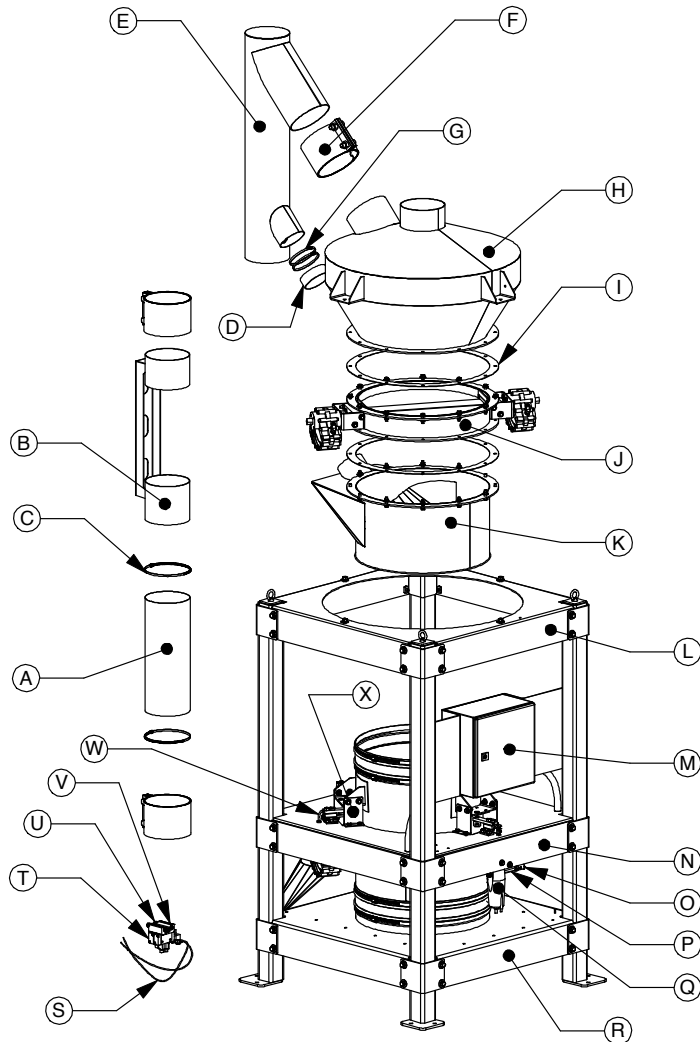

SCALE TOP EXPLODED
DESCRIPTION:



KICE INDUSTRIES, INC.

5500 MILL HEIGHTS DR. WICHITA, KANSAS 67219
PH: (316) 744-7151 FAX: (316) 744- 7355

JTK
DWN:

12-8-08
DATE:

SCL-5005
DWG. NO.

PARTS LIST			
	QTY	ITEM	PART #
A	4	HOSE CLAMP; QUICK RELEASE; Ø22 1/2" - Ø24 1/4"	5215K35
B	2	ISOLATION SLEEVE	IS24.25x6.5NYL
C	1	CONTROL PANEL	SCL-224-2410
D	1	24-500 WEIGH CHAMBER 24-1000 WIEGH CHAMBER 24-1500 WEIGH CHAMBER 24-2000 WEIGH CHAMBER	SCL-224-2300 SCL-224-2310 SCL-224-2320 SCL-224-2330

PARTS LIST			
	QTY	ITEM	PART #
E	1	TOP VALVE SHROUD	SCL-224-2030
F	1	MALE HEX NIPPLE	6-6MHLN-B-4.0
G	1	AIR FILTER	2003N-1B1-DX
H	1	3/8" VENTED LOCKABLE BALL VALVE	VVP500P-6
I	4	DS24 VALVE GASKET	GSKTSCL-920-3020
J	2	DS24 FLAP VALVE	SCL-224-2000
K	1	BOTTOM VALVE SHROUD	SCL-224-2040

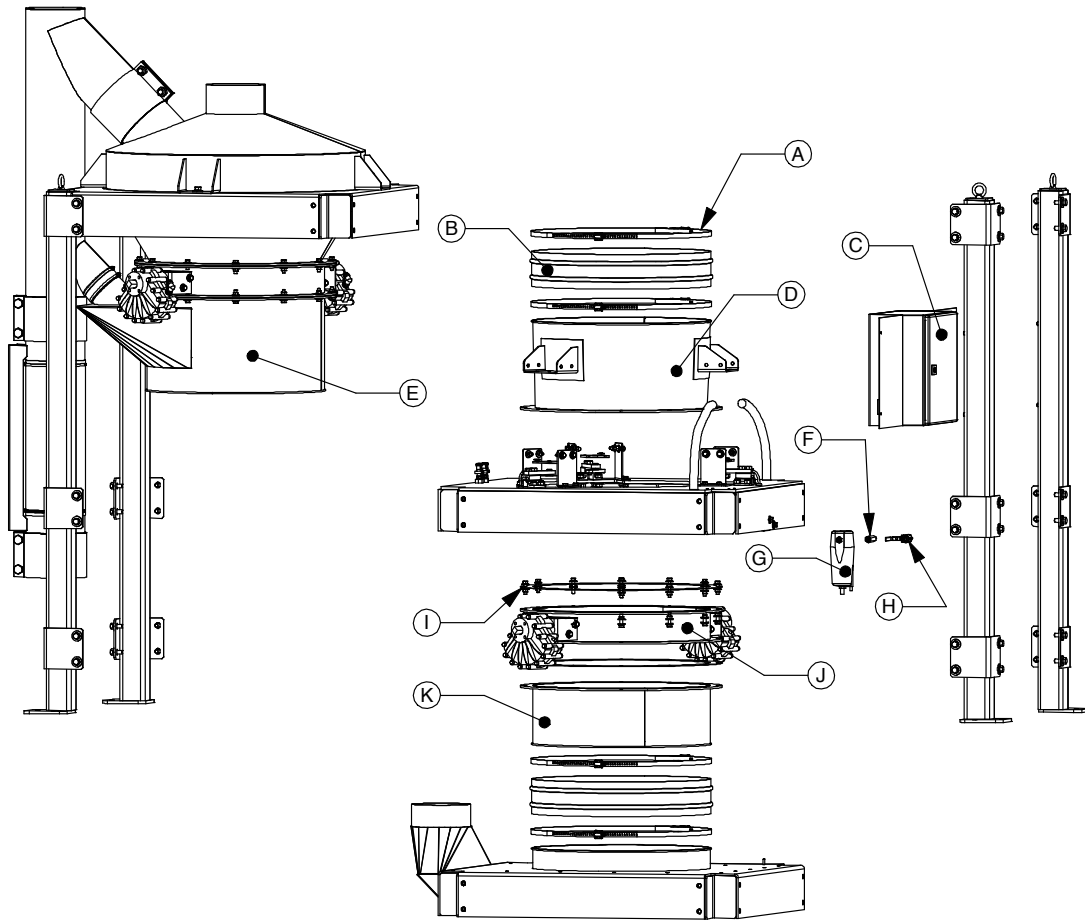

SCALE SIDE EXPLODED
DESCRIPTION:



KICE INDUSTRIES, INC.

5500 MILL HEIGHTS DR. WICHITA, KANSAS 67219
PH: (316) 744-7151 FAX: (316) 744- 7355

JTK
DWN:

10-12-09
DATE:

SCL-5006
DWG. NO.

PARTS LIST (PER VALVE)			
	QTY	ITEM	PART #
A	1	FLAP VALVE (WM)	SCL-224-2010
B	8	3/8" SPRING LOCK WASHER	10000556
C	4	ARBOR SHIM	25255
D	2	PIVOT BLOCK ASSEMBLY	SCL-224-2020
E	2	SPRING PIN; Ø3/16" x 2" LG.	10000071
F	8	3/8"-16 HEX NUT	10000508
G	8	EXTERNAL RETAINING RING	98410A145
H	2	ACTUATOR COUPLING	SCL-224-3010
I	16	3/8"-16 x 3/4" HEX BOLT	10000153
J	2	ACTUATOR MOUNTING BRACKET	SCL-224-3010
K	2	ROTARY ACTUATOR	099-100
L	2	CUP POINT SET SCREW 1/4"-20 x 1/4"	10000815

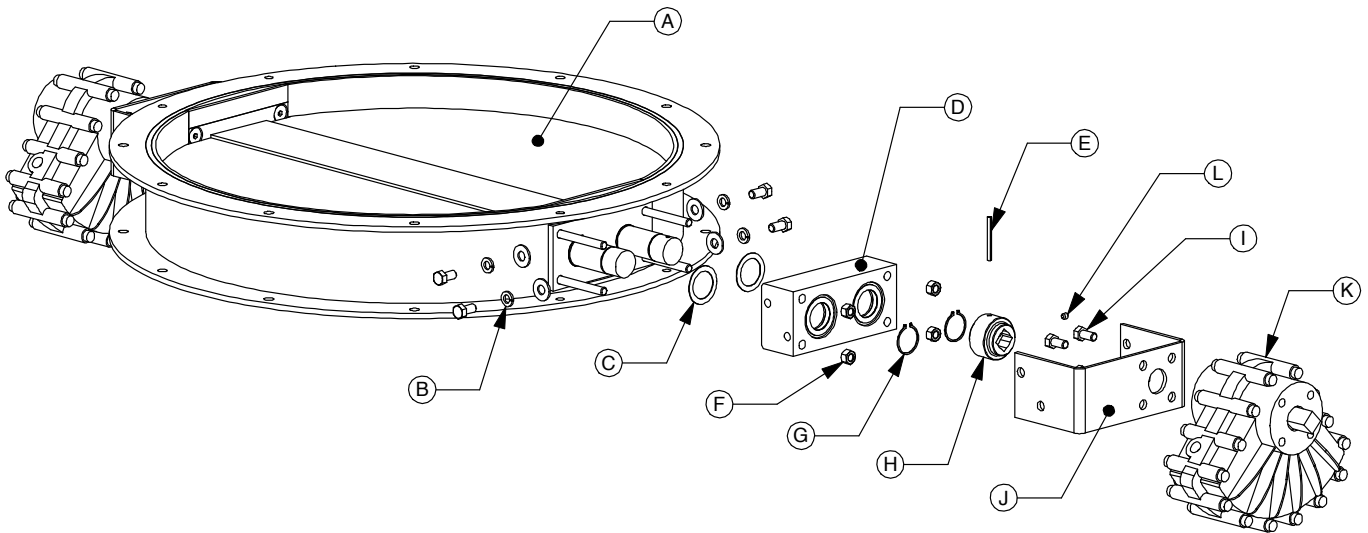

SCALE VALVE
DESCRIPTION:



KICE INDUSTRIES, INC.

5500 MILL HEIGHTS DR. WICHITA, KANSAS 67219
PH: (316) 744-7151 FAX: (316) 744- 7355

JTK
DWN:

12-23-08
DATE:

SCL-5007
DWG. NO.

PARTS LIST (PER VALVE)			
	QTY	ITEM	PART #
A	4	ARBOR SHIM	25255
B	8	SHAFT SEAL	CR 12456
C	4	SPACER	SCL-224-3009
D	4	BALL BUSHING	GEZ-104-ES-2RS
E	2	PIVOT BLOCK	SCL-224-3008

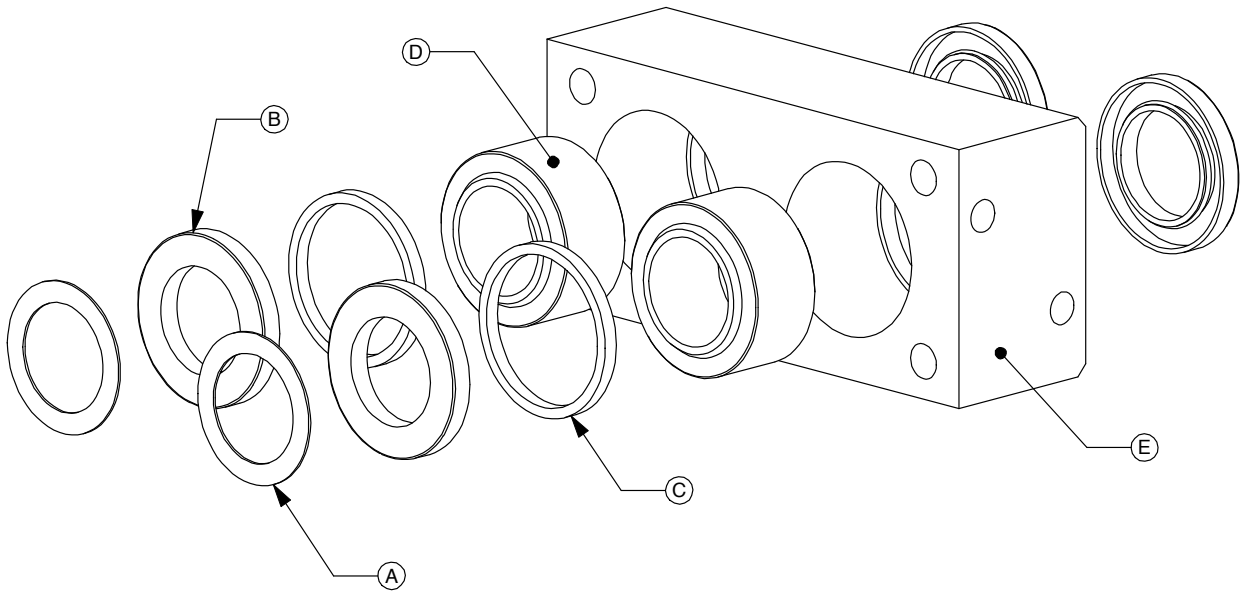

PIVOT BLOCK
DESCRIPTION:



KICE INDUSTRIES, INC.

5500 MILL HEIGHTS DR. WICHITA, KANSAS 67219
PH: (316) 744-7151 FAX: (316) 744- 7355

JTK
DWN:

12-23-08
DATE:

SCL-5008
DWG. NO.

GLOSSARY OF TERMS

Term	Definition	Page #
Air actuator	Pneumatic powered rotary actuator that provides 90 degrees of rotation to cycle the dump valves.	36, 37, 40
Batch Mode	Allows a set amount of product to flow through the scale, then stop flow.	11, 12, 14
Bypass mode	A mode which allows product to pass through the scale without being weighed or restricted.	13, 21, 23, 34, 40
Dump valve	Valve consisting of two semicircle flaps that hold product in place while weighing; then opening to allow the product to move forward in the process.	4, 5, 37
Isolation sleeve	A narrow loop of fabric installed above and below the weigh chamber to isolate the desired region from the rest of the scale. This enables just the weigh chamber to be supported by the load cells allowing true weight to be determined.	37, 39
Load cell	An electronic device that converts deflection of a cantilever into an electronic signal that can calculate weight.	9, 20, 21, 23, 24, 38, 39, 40
Local mode	A mode which allows control from the PanelView. Product will be weighed as it passes through the scale.	9, 10, 13, 33, 40
PanelView	Allen-Bradley model name. Operator interface	3, 4, 8, 9
Remote mode	A mode which allows control from the process computer or the PanelView. Product will be weighed as it passes through the scale.	9, 10, 21, 23, 33, 34
Weigh chamber	The portion of the scale that holds product that is being weighed, located between the top isolation sleeve and the bottom dump valve.	4
Yield management system	Optional programming change which allows yields to be calculated as product flows through the scale.	

APPENDIX

- **ELECTRIC SCHEMATIC**
- **PNEUMATIC SCHEMATIC**

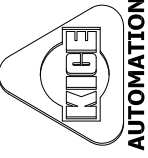

SYMBOLS LEGEND

OPERATOR LEGEND

- BA - BELT ALIGNMENT
- BE - BUCKET ELEVATOR
- CB - CIRCUIT BREAKER
- CC - CONTACTOR
- CD - CIRCUIT DISTRIBUTION BLOCK
- CE - CHOKE DETECT
- CL - CONTINUOUS LEVEL
- CT - CURRENT TRANSDUCER
- DC - DRIVE LIGHT
- DI - DIODE
- DP - DISTRIBUTION PANEL
- DS - DOOR SWITCH/BREAKER INTERLOCK
- EA - ELECTRIC ACTUATOR
- ENS - ETHERNET SWITCH
- ES - EMERGENCY STOP
- F - FUSE
- FB - FLOW BALANCE
- FC - FILTER CONTAMINATION SENSOR
- FI - FLOW METER
- FS - FLOW SWITCH/SENSOR
- FN - FLOW METER
- FP - ILLUMINATED PUSH/PULL
- IP - KEYPAD
- LI - LEVEL INDICATOR PROBE
- LX - LEVEL INDICATOR PROXIMITY
- LL - LIQUID LEVEL SWITCH
- LP - LIGHTING PANEL
- LSW - LIMIT SWITCH
- LSK - LIMIT PROXIMITY
- LT - PILOT LIGHT
- M - MOTOR
- MD - MESSAGE DISPLAY
- MIS - MOTOR INDICATOR SENSOR
- MIX - MOTOR INDICATOR PROXIMITY
- MS - MOTOR STARTER
- MSB - MAIN SWITCHBOARD
- MT - MOTOR WIRE TRANSDUCER
- OI - OPERATOR INTERFACE
- OL - OVERLOAD
- PAC - PROGRAMMABLE AUTOMATION CONTROLLER
- PB - PUSH BUTTON
- PB - PRINTED CIRCUIT BOARD
- PD - PROPORTIONAL DEVICE
- PE - POWER DISTRIBUTION BLOCK
- PE - PHOTO EYE
- PI - ILLUMINATED PUSH BUTTON
- PL - CONTINUOUS LEVEL
- PL - POSITION INDICATE TRANSMITTER
- PL - PRY CONTACT
- PP - PNEUMATIC LOGIC CONTROLLER
- PP - PANEL METER
- PP - PUSH/PULL
- PS - PRESSURE TRANSDUCER
- PSW - PRESSURE SWITCH
- PT - POTENTIOMETER
- R - RELAY
- RAD - REMOTE ACCESS DEVICE
- RP - RECEIPTABLE PANEL
- SC - SOLID
- SNC - SMART MOTOR CONTROLLER (SOFT START)
- SPD - SUPPLIES/HART PROTECTION DEVICE
- SS - SURGE SUPPRESSOR
- SSS - SOLID STATE STARTER
- SV - SOLENOID VALVE
- T - TIMER
- TC - THERMOCOUPLE
- TR - TRIP/RELAY
- TST - TEMPERATURE TRANSMITTER
- TSW - TEMPERATURE SWITCH
- UPS - UNINTERRUPTIBLE POWER SUPPLY
- VFD - VARIABLE FREQUENCY DRIVE
- VS - VIBRATION SWITCH
- XD - TRANSFORMER
- XP - TRANSDUCER
- ZP - 2 POSITION ILLUM. SELECTOR SWITCH
- ZI - 2 POSITION ILLUM. SELECTOR SWITCH
- ZP - 2 POSITION SELECTOR SWITCH
- ZI - 2 POSITION SPRING RETURN SELECTOR SWITCH
- ZP - 3 POSITION ILLUM. SELECTOR SWITCH
- ZI - 3 POSITION ILLUM. SELECTOR SWITCH
- ZP - 4 POSITION SELECTOR SWITCH

SCHEMATIC SYMBOLS

LIQUID LEVEL SWITCH - NORMALLY OPEN

 - LIQUID LEVEL SWITCH - NORMALLY OPEN

LIQUID LEVEL SWITCH - NORMALLY CLOSED

 - LIQUID LEVEL SWITCH - NORMALLY CLOSED

LIMIT SWITCH - NORMALLY OPEN

 - LIMIT SWITCH - NORMALLY OPEN

LIMIT SWITCH - NORMALLY OPEN HELD CLOSED

 - LIMIT SWITCH - NORMALLY OPEN HELD CLOSED

LIMIT SWITCH - NORMALLY CLOSED

 - LIMIT SWITCH - NORMALLY CLOSED

LIMIT SWITCH - NORMALLY CLOSED HELD OPEN

 - LIMIT SWITCH - NORMALLY CLOSED HELD OPEN

PRESSURE SWITCH - NORMALLY OPEN

 - PRESSURE SWITCH - NORMALLY OPEN

PRESSURE SWITCH - NORMALLY CLOSED

 - PRESSURE SWITCH - NORMALLY CLOSED

TEMPERATURE SWITCH - NORMALLY OPEN

 - TEMPERATURE SWITCH - NORMALLY OPEN

TEMPERATURE SWITCH - NORMALLY CLOSED

 - TEMPERATURE SWITCH - NORMALLY CLOSED

PUSH BUTTON - NORMALLY OPEN

 - PUSH BUTTON - NORMALLY OPEN

PUSH BUTTON - NORMALLY CLOSED

 - PUSH BUTTON - NORMALLY CLOSED

2 POSITION SELECTOR SWITCH - NORMALLY OPEN

 - 2 POSITION SELECTOR SWITCH - NORMALLY OPEN

2 POSITION SELECTOR SWITCH - NORMALLY CLOSED

 - 2 POSITION SELECTOR SWITCH - NORMALLY CLOSED

3 POSITION SELECTOR SWITCH - NORMALLY OPEN

 - 3 POSITION SELECTOR SWITCH - NORMALLY OPEN

3 POSITION SELECTOR SWITCH - NORMALLY CLOSED

 - 3 POSITION SELECTOR SWITCH - NORMALLY CLOSED

SOLENOID VALVE

 - SOLENOID VALVE

LETTER INDICATES TYPE OF DEVICE, REFER TO SYMBOL ABBREVIATION FOR DEVICE TYPE

CONTACT - NORMALLY OPEN, LETTER INDICATES TYPE OF CONTACT, REFER TO SYMBOL ABBREVIATION FOR CONTACT TYPE

CONTACT - NORMALLY CLOSED, LETTER INDICATES TYPE OF CONTACT, REFER TO SYMBOL ABBREVIATION FOR CONTACT TYPE

CIRCUIT BREAKER - NUMBER INDICATES AMPERAGE

PILOT LIGHT OR ILLUMINATED PUSH BUTTON, REFER TO SYMBOL ABBREVIATION FOR DEVICE TYPE LETTER INDICATES COLOR

HORN

 - HORN

RESISTOR - NUMBER INDICATES RESISTANCE

 - RESISTOR - NUMBER INDICATES RESISTANCE

FUSE - NUMBER INDICATES AMPERAGE

 - FUSE - NUMBER INDICATES AMPERAGE

POTENTIOMETER

 - POTENTIOMETER

WIRE CONNECTOR

 - WIRE CONNECTOR

TERMINAL BLOCK

 - TERMINAL BLOCK

SHIELDED CONDUCTOR

 - SHIELDED CONDUCTOR

SURGE SUPPRESSOR

 - SURGE SUPPRESSOR

CONTROL TRANSFORMER

 - CONTROL TRANSFORMER

DRAWING SET LAYOUT

- A - DRAWING DIRECTORY
- SYMBOLS LEGEND
- DRIVE CONFIGURATION SETTINGS
- AREA CLASSIFICATION DRAWINGS
- CONTROL WIRING SCHEMATICS
- PAC SYSTEM OVERVIEW
- PAC COMMUNICATION CONNECTION DIAGRAMS
- I/O AND PACK DETAILS
- CONSOLE GRAPHICS
- OPERATOR LAYOUT
- BACKPLATE LAYOUT
- ENCLOSURE LAYOUT
- FLOW DIAGRAM
- MCC LAYOUT
- I/O MODULE SCHEMATICS
- MAIN POWER ONE-LINES
- MCC ONE-LINE & ELEVATIONS
- CONDUIT RISER DIAGRAMS
- CONDUIT & CABLE SCHEDULES

I/O WIRING COLOR KEY

I/O NUMBER	WIRE COLOR
00	BLK
01	W
02	GR
03	G
04	O
05	BRN
06	Y
07	R/BK
08	GRK
09	BLK
10	BLK
11	BRN
12	Y
13	GR
14	BLW
15	BRK

BELDEN CABLE #8619

WIRE COLOR LEGEND

- BL - BLACK
- BLU - BLUE
- BR - BROWN
- GR - GREEN
- GY - GREY
- OR - ORANGE
- R - RED
- V - VIOLET
- W - WHITE
- Y - YELLOW

MOTOR BRANCH CIRCUIT WIRING SYMBOLS

CIRCUIT PROTECTION

 3-POLE NEMA CIRCUIT BREAKER

3-POLE IEC CIRCUIT BREAKER

 3-POLE IEC CIRCUIT BREAKER

CONTACTOR

 NEMA CONTACTOR

IEC CONTACTOR

 IEC CONTACTOR

OVERLOAD PROTECTION

 NEMA THERMAL/MAGNETIC OVERLOAD RELAY

IEC THERMAL/MAGNETIC OVERLOAD RELAY

 IEC THERMAL/MAGNETIC OVERLOAD RELAY

JOB TITLE
KICE DUMP SCALE STANDARD (REV. 3)

CUSTOMER NAME & LOCATION
 KICE INDUSTRIES, INC. WICHITA, KS

SITE NAME & LOCATION
 KICE INDUSTRIES, INC. WICHITA, KS

DRAWN BY
 MMF

APPROVED BY
 SA

DATE
 4/21/09

PLANT SCALE
 1.00

SALES ORDER NO.
 STANDARDS

DWG TITLE
 SYMBOLS LEGEND

DWG NO
 A-2

FOR CONSTRUCTION

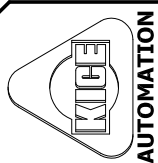

NOTES:
 CONTROL PANEL VOLTAGE _____
 FIELD WIRING _____
 WIRE SIZE _____
 WIRE COLOR _____
 WIRE TYPE _____
 SP# = SUPPLEMENTAL PROTECTION DEVICE

REV.	DATE	BY

PROJECT: **KICE DUMP SCALE STANDARD (REV. 3)**
 CUSTOMER NAME & LOCATION: **KICE INDUSTRIES, INC. WICHITA, KS**
 SITE NAME & LOCATION: **KICE INDUSTRIES, INC. WICHITA, KS**

SCALE: **1:1** (DRAWING)
 MDT TO SCALE: **1:1** (IMF)
 DATE: **4/21/09** APPROVED BY: **SA**
 PLOT SCALE: **1:100** MINOR REVISION: _____
 SALES ORDER NO.: **000**
 STANDARDS: _____
 DRAWING TITLE: **CONTROL CIRCUIT DISTRIBUTION SCHEMATIC**
 DRAW NO: _____

C-1

FOR CONSTRUCTION

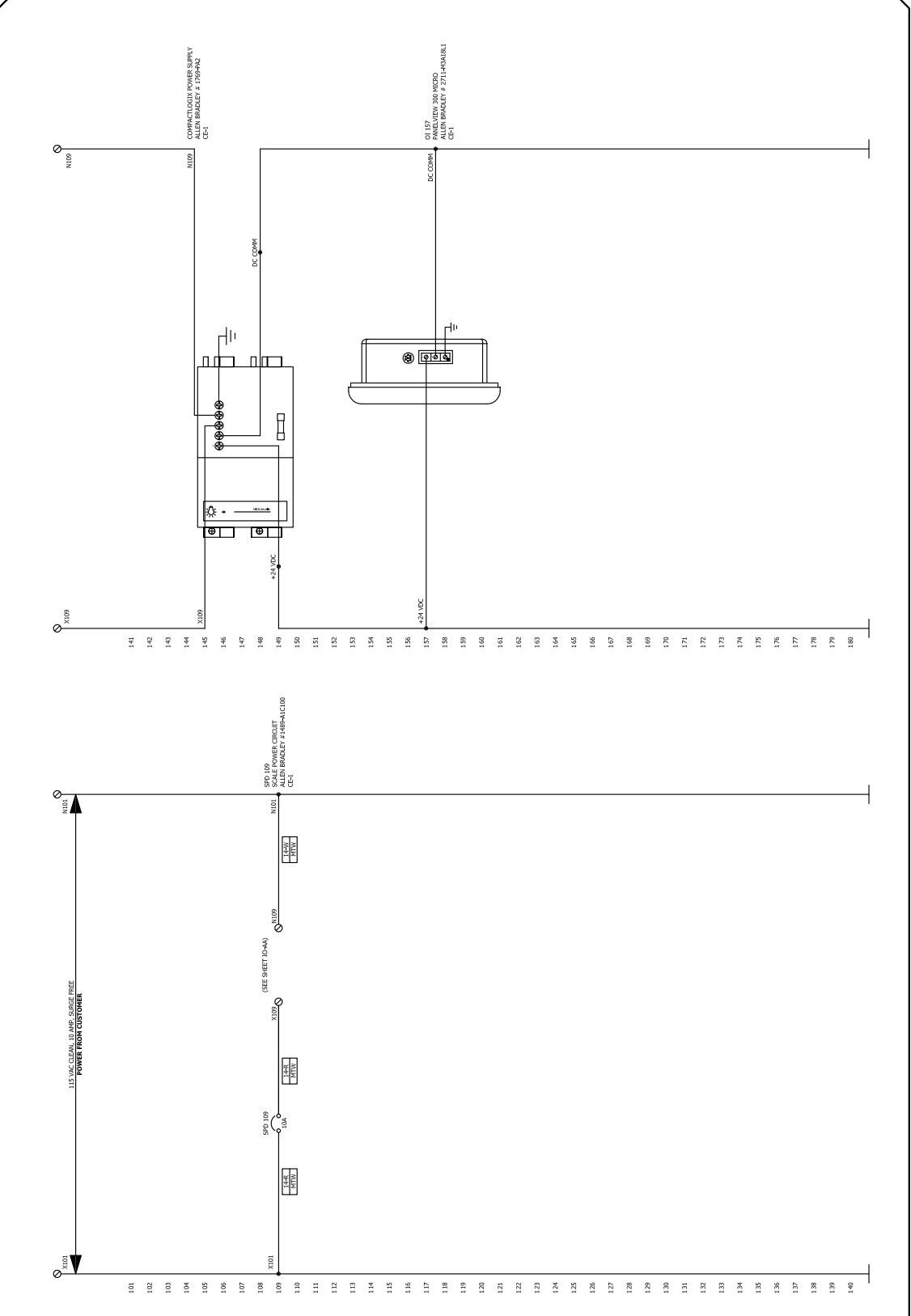

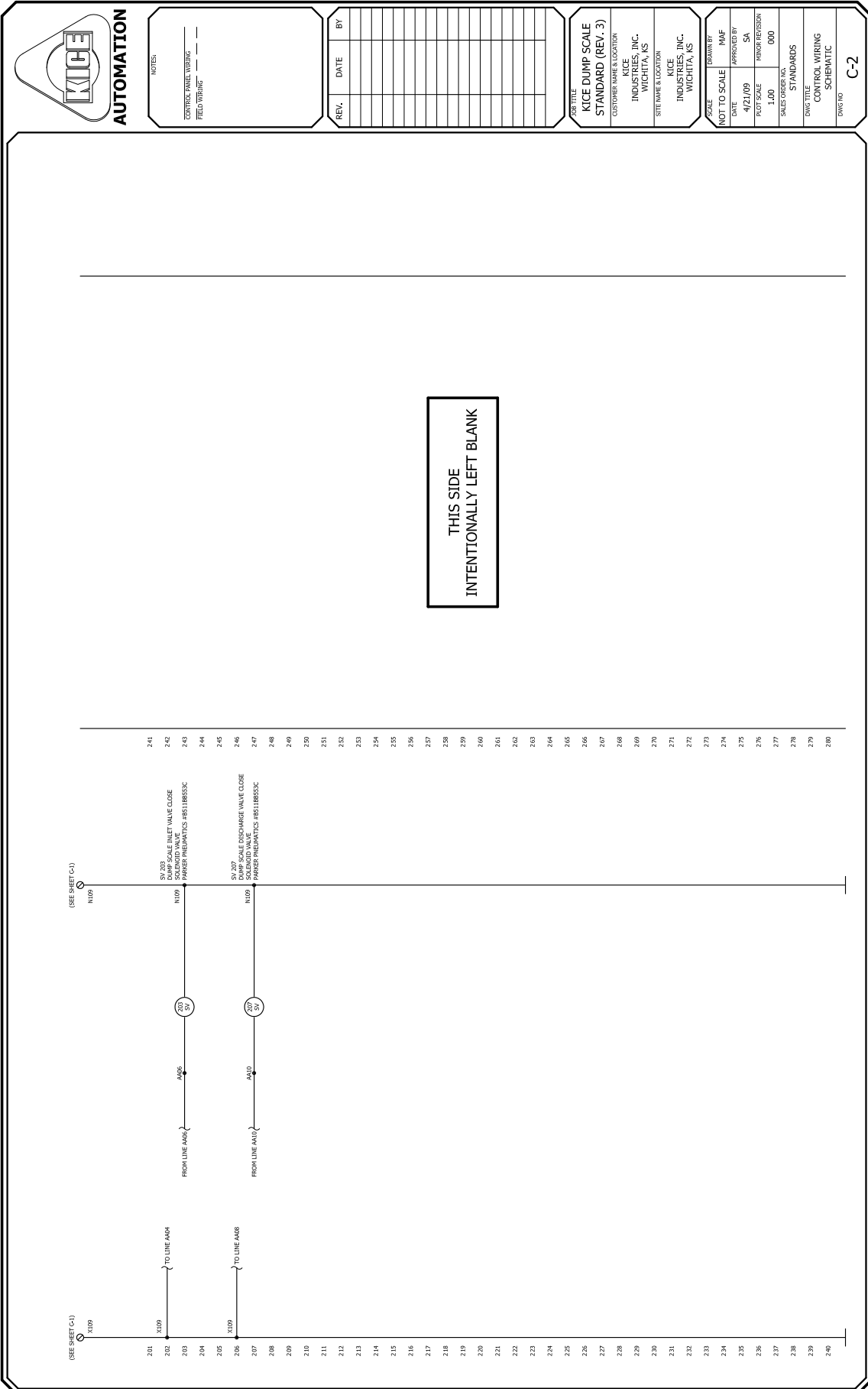

FOR CONSTRUCTION

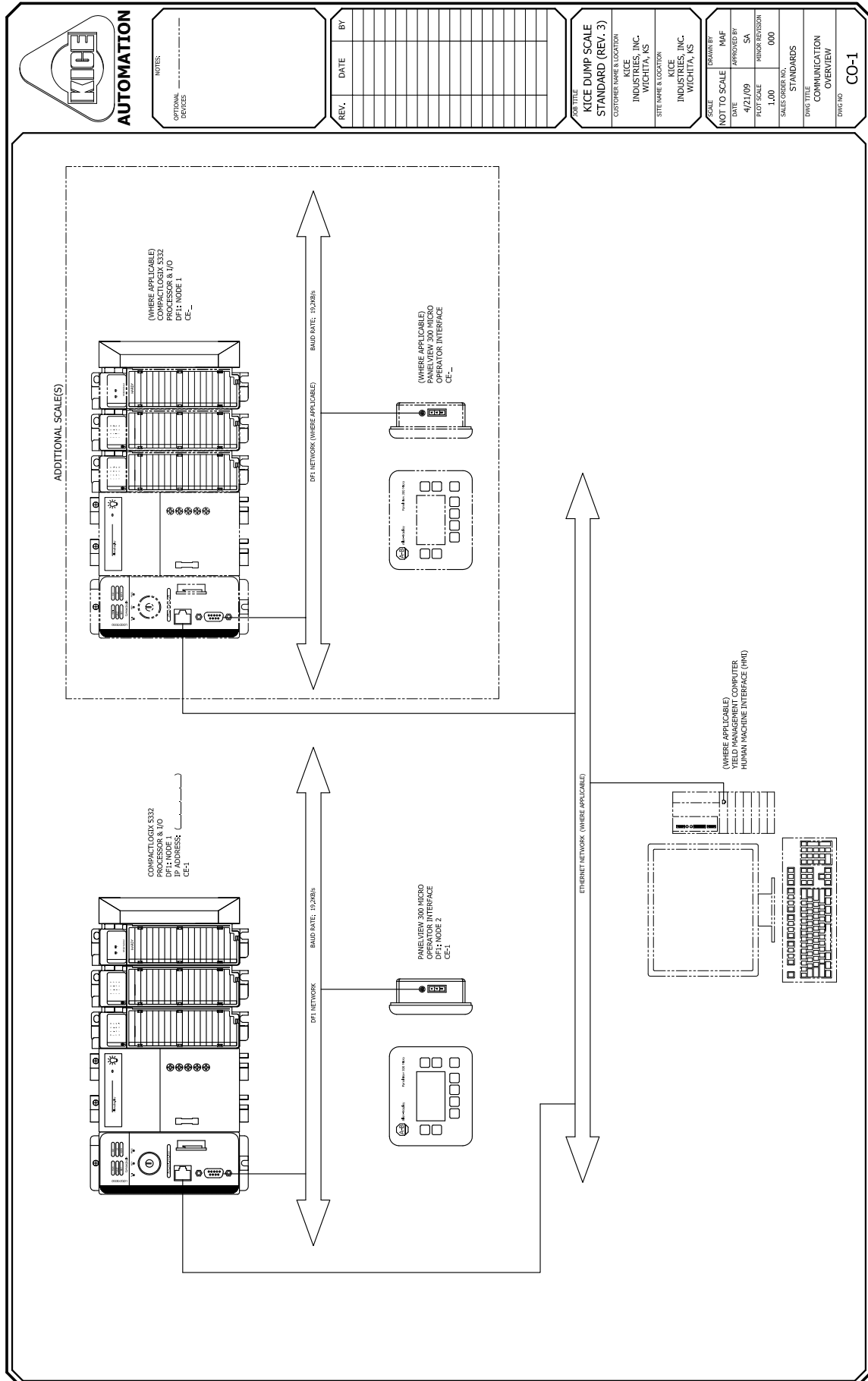

FOR CONSTRUCTION

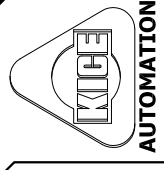

NOTES:
OPTIONAL
DRIVES

REV.	DATE	BY

SCALE TITLE
KICE DUMP SCALE
STANDARD (REV. 3)

CUSTOMER NAME & LOCATION
KICE
INDUSTRIES, INC.
WICHITA, KS

SITE NAME & LOCATION
KICE
INDUSTRIES, INC.
WICHITA, KS

SCALE	ISSUED BY	INBAF
NOT TO SCALE	APPROVED BY	SA
DATE	PROJECT NO.	000
4/21/09	STANDARDS	
PLOT SCALE	DWG. TITLE	COMMUNICATION
1:00	OVERVIEW	
SALES DRESSING	DWG. NO.	CO-1

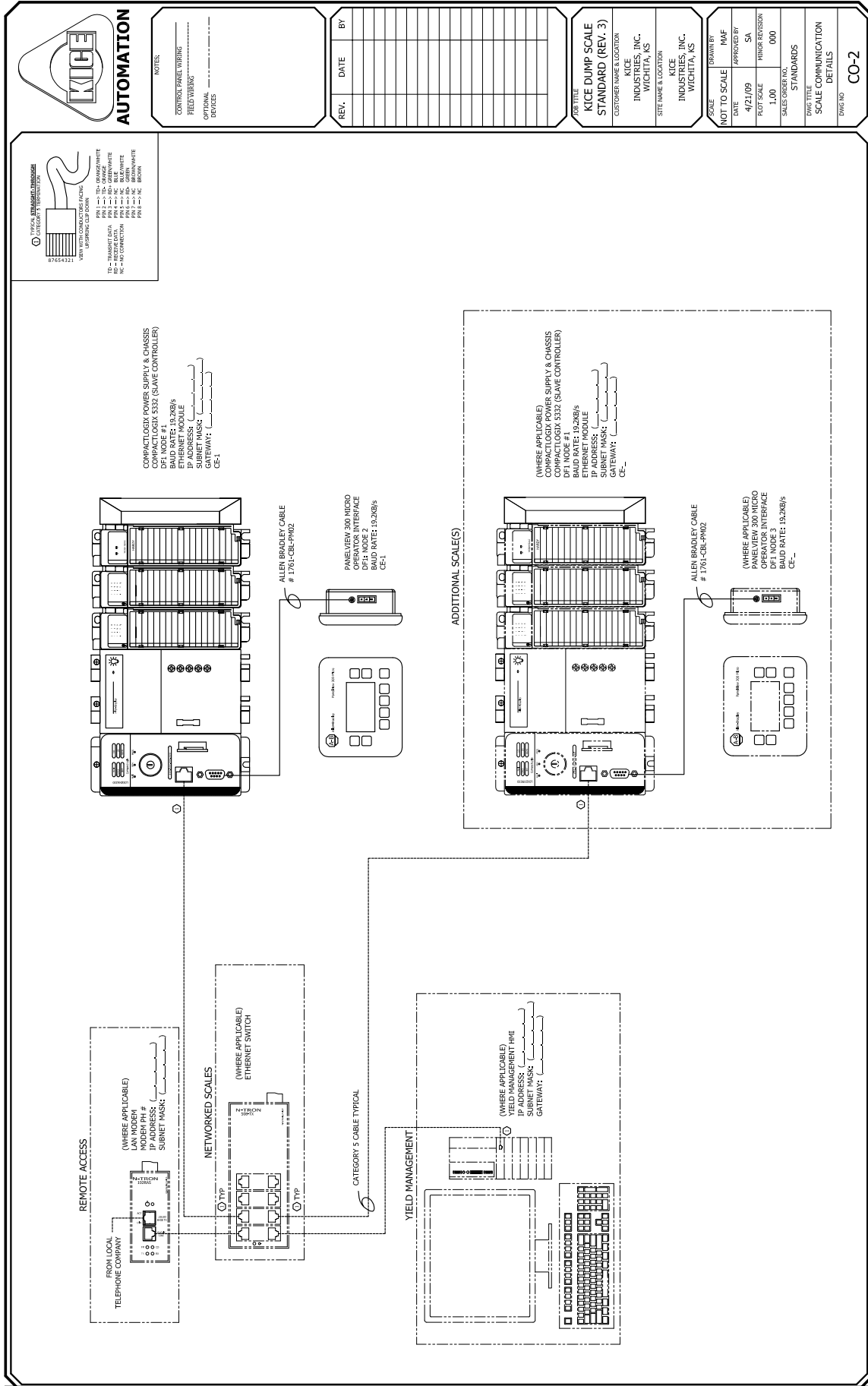

FOR CONSTRUCTION

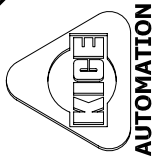
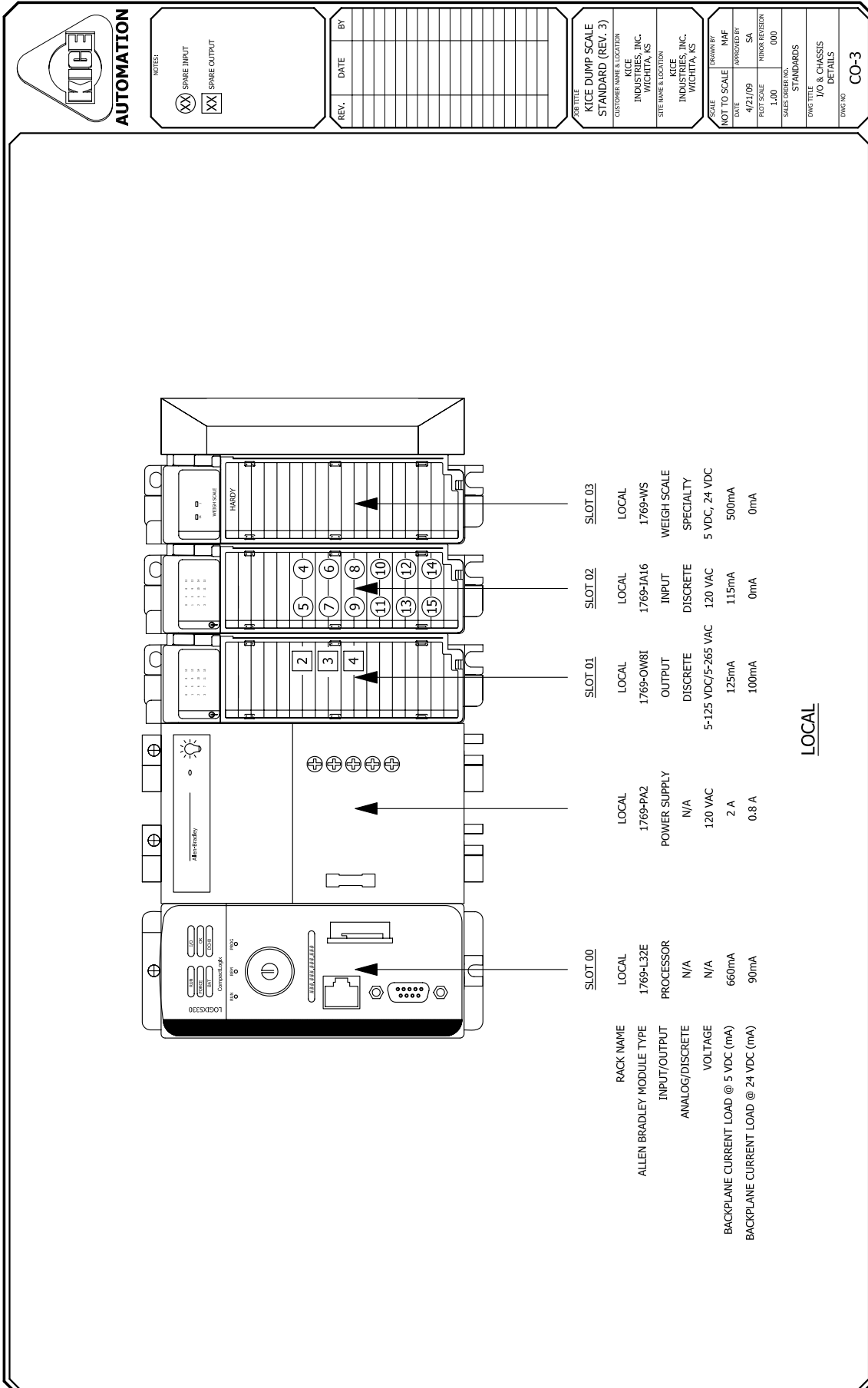

NOTES:
XX SPARE INPUT
XX SPARE OUTPUT

REV.	DATE	BY

PART TITLE: KICE DUMP SCALE STANDARD (REV. 3)
CUSTOMER NAME & LOCATION: KICE INDUSTRIES, INC. WICHITA, KS
SITE NAME & LOCATION: KICE INDUSTRIES, INC. WICHITA, KS

SIZE: 1769-WS
NOT TO SCALE: MAF
DATE: 4/21/09
APPROVED BY: SA
PLOT SCALE: 1:00
NUMBER REVISION: 000
SALES ORDER NO.:
STANDARDS:
DWS TITLE: I/O & CHASSIS DETAILS
DWS NO: CO-3

FOR CONSTRUCTION

LOCAL

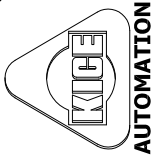

NOTES:
 * TWO WIRE TERMINATION
 SCALE TERMINATIONS
 TYPICAL FOR ALL SCALES WITH
 HANOVY INSTRUMENTS CELL CELLS

REV.	DATE	BY

JOB TITLE
**KICE DUMP SCALE
 STANDARD (REV. 3)**

CUSTOMER NAME & LOCATION
 KICE
 INDUSTRIES, INC.
 WICHITA, KS

SITE NAME & LOCATION
 KICE
 INDUSTRIES, INC.
 WICHITA, KS

SCALE
 NOT TO SCALE

DRAWN BY
 MAF

DATE
 4/21/09

APPROVED BY
 SA

PLOT SCALE
 1:00

HANOVY REVISION
 000

SALES ORDER NO.
 STANDARDS

DWG TITLE
 LOAD CELL
 CONNECTION DIAGRAM

DWG NO.
CO-4

FOR CONSTRUCTION

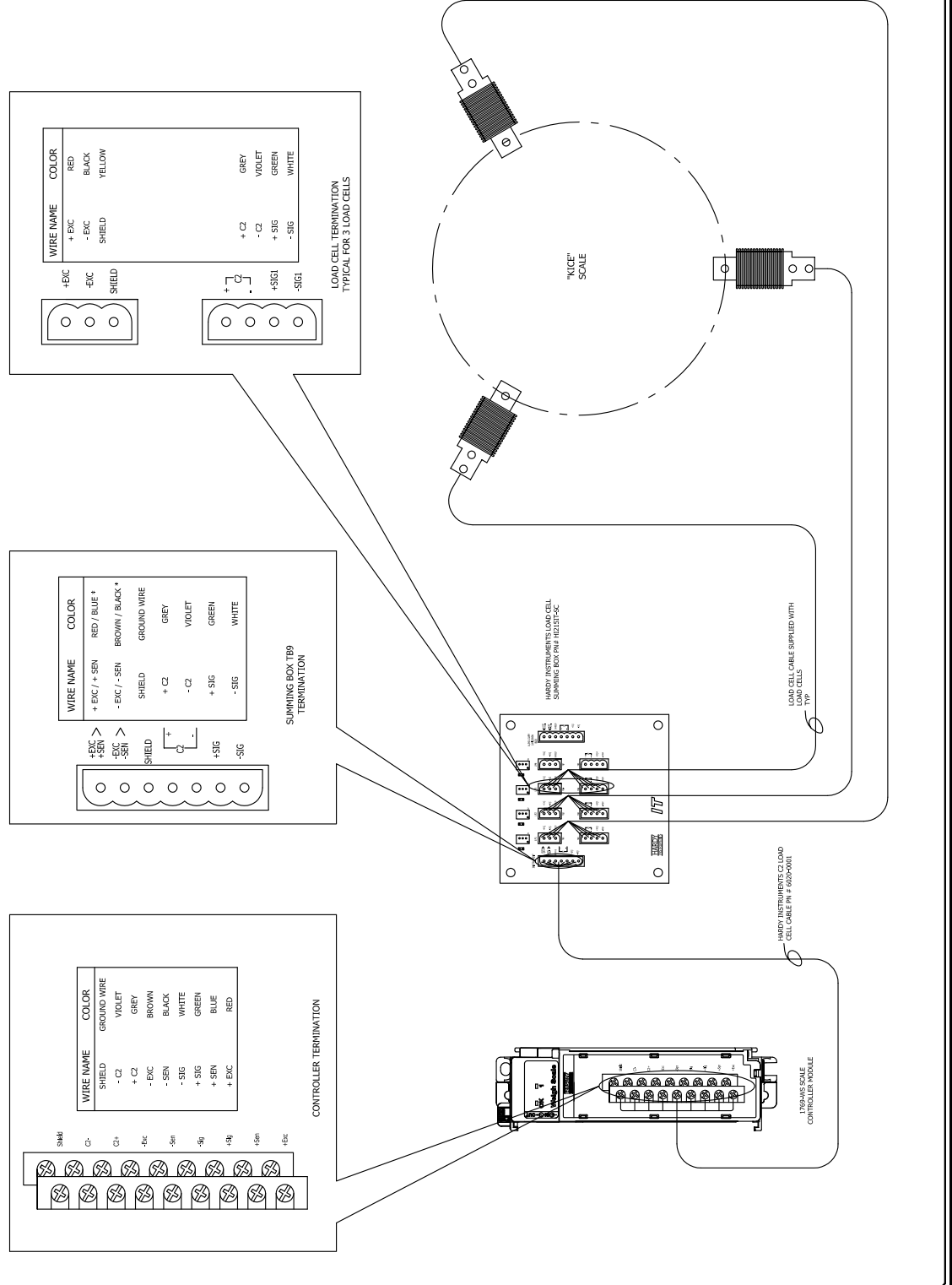

AUTOMATION

NOTES:

SCHMATIC LINE #
- DEVICE ABBREVIATION

QUANTITY
- MATERIAL
- ITEM NUMBER

REV. DATE BY

DATE TITLE
KICE DUMP SCALE STANDARD (REV. 3)

CUSTOMER NAME & LOCATION
KICE INDUSTRIES, INC.
WICHITA, KS

SITE NAME & LOCATION
KICE INDUSTRIES, INC.
WICHITA, KS

SCALE 1/4" = 10"
DATE 4/21/09
APPROVED BY SA
PRICE \$A
PURCH. QUANTITY 0.25
PURCH. REFERENCE 000

SALES ORDER NO.
STANDARDS
CONTROL ENCLOSURE
CE-1 DETAILS
DWG NO E-1

DOOR INTERIOR

FRONT EXTERIOR

FRONT INTERIOR

ITEM #	DESCRIPTION	QTY	REV.	QTY	REV.	QTY
1200	Gate Reader (1 per) (0.0 Amps) (L490)	1		1	1	
1205	Communication Cable (S2 Pin) (40420) (S4 Pin) (5048) (3m)	1		1	1	
1215	Relay Module (1 per) (1204) (24VDC) (1204)	1		1	1	
1218	Relay Module (1 per) (1204) (24VDC) (1204)	1		1	1	
1220	Communication Cable (S2 Pin) (40420) (S4 Pin) (5048) (3m)	1		1	1	
1225	Relay Module (1 per) (1204) (24VDC) (1204)	1		1	1	
1230	Communication Cable (S2 Pin) (40420) (S4 Pin) (5048) (3m)	1		1	1	
1235	Relay Module (1 per) (1204) (24VDC) (1204)	1		1	1	
1240	Communication Cable (S2 Pin) (40420) (S4 Pin) (5048) (3m)	1		1	1	
1245	Relay Module (1 per) (1204) (24VDC) (1204)	1		1	1	
1250	Communication Cable (S2 Pin) (40420) (S4 Pin) (5048) (3m)	1		1	1	
1255	Relay Module (1 per) (1204) (24VDC) (1204)	1		1	1	
1260	Communication Cable (S2 Pin) (40420) (S4 Pin) (5048) (3m)	1		1	1	
1265	Relay Module (1 per) (1204) (24VDC) (1204)	1		1	1	

FOR CONSTRUCTION

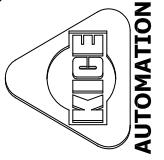

NOTES:
 1. QUANTITY
 2. QUANTITY
 3. ITEM NUMBER

REV.	DATE	BY	DWG
1	3/5/10		

FOR TITLE
 KICE DUMP SCALE
 STANDARD (REV. 3)

CUSTOMER NAME & LOCATION
 KICE
 INDUSTRIES, INC.
 WICHITA, KS

SITE NAME & LOCATION
 KICE
 INDUSTRIES, INC.
 WICHITA, KS

SCALE
 1/2" = 1"

DATE
 4/21/09

PROJ SCALE
 0.5

SALES ORDER NO.
 090

STANDARDS

DWG TITLE
 SUMMING BOARD
 MOUNTING BRACKET

DWG NO.
 E-2

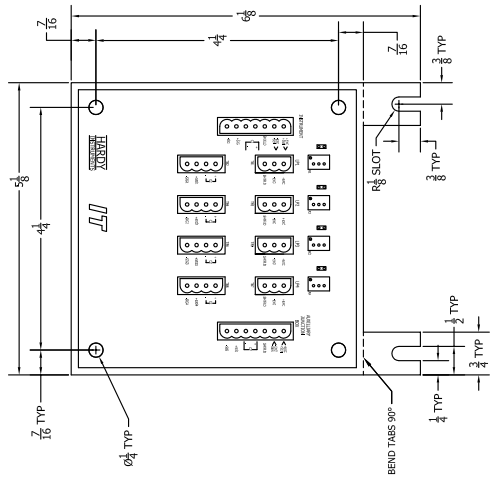
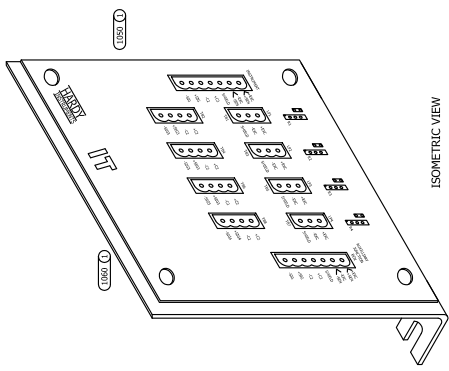

FLAT PATTERN
 (10 ga. STAINLESS STEEL)

ITEM	MFG.	DESCRIPTION	CATALOG #	QTY
1000	Allen Bradley	1 pk. (10.0 amp)	498A-LC100	1
1005	Allen Bradley	Communicator Cable (8 Pin) (M20) to 9 Pin (M28, 20)	1791-C8-M902	1
1010	Allen Bradley	CompuLogix™ Terminal End Cap (Right end)	1799-6205	1
1015	Allen Bradley	CompuLogix™ Driver Input Expansion Module (DSI-MC)	1799-3415	1
1020	Allen Bradley	CompuLogix™ 5331 Processor (250k Memory, 1 Slot) (5331-101)	1799-3236	1
1025	Allen Bradley	CompuLogix™ Power Supply (120V/240VAC 2 Amp @ 5 VDC)	1799-2432	1
1030	Allen Bradley	CompuLogix™ 200 Micro-VIPET Communicator	2111-M010ELL	1
1040	Allen Bradley	MSM-A Endurance Watchdog (16" x 16" x 8")	WH65-0690C	1
1045	Allen Bradley	Endurance-Mounting Bracket (1640)	ML 1590-0002	1
1050	Allen Bradley	Load Cell Junction PCB Board with IT (No Lockout)	1642-1010-01	1
1055	Allen Bradley	CompuLogix™ Watch Scale Module	1642-1010-02	1
1060	Allen Bradley	CompuLogix™ Mounting Bracket (10 ga. 304/316 SS)	1799-905	1

FOR CONSTRUCTION

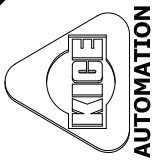

NOTES:

REV.	DATE	BY

PROJECT TITLE	
KICE DUMP SCALE STANDARD (REV. 3)	
CUSTOMER NAME & LOCATION	
KICE INDUSTRIES, INC. WICHITA, KS	
SITE NAME & LOCATION	
KICE INDUSTRIES, INC. WICHITA, KS	
SCALE	AS SHOWN
NOT TO SCALE	MAF
DATE	APPROVED BY
4/2/09	SA
PROJECT NO.	PROJECT NO.
1-00	000
SALES ORDER NO.	SALES ORDER NO.
	000
STANDARDS	
DWG. TITLE	
PLUMBING DIAGRAM FOR SCALE	
DWG. NO.	
F-1	

ITEM	DESCRIPTION	QTY
2401	Mulder / Fibre Concrete 3/8" NPT	2
2402	3/8" NPT Plug Socket Head / Brass	3
2403	3/8" Flare Tee Hub-to- Stainless Steel	1
2404	Subhead Flange fitting 3/8" NPT to 3/8" Tube	2
2405	Subhead Valve Single, 4-Way, 2 Position, Air Return	2
2406	3/8" Blue Polyurethane Tubing	75
2407	20' Blue Polyurethane Tubing 1/2" x 3/8"	1
2408	3/8" Full Port, Lockable, Vented, Ball Valve	1
2409	Union Y Nib- Connector	2
2410	Nib Elbow- Steel	2
2411	Nib Tee- Steel 1/4" NPT to 3/8" Tube	2
2412	Nib connector 1/4" NPT to 3/8" Tube	2
2413	Nib Connector 3/8" NPT to 3/8" Tube	2

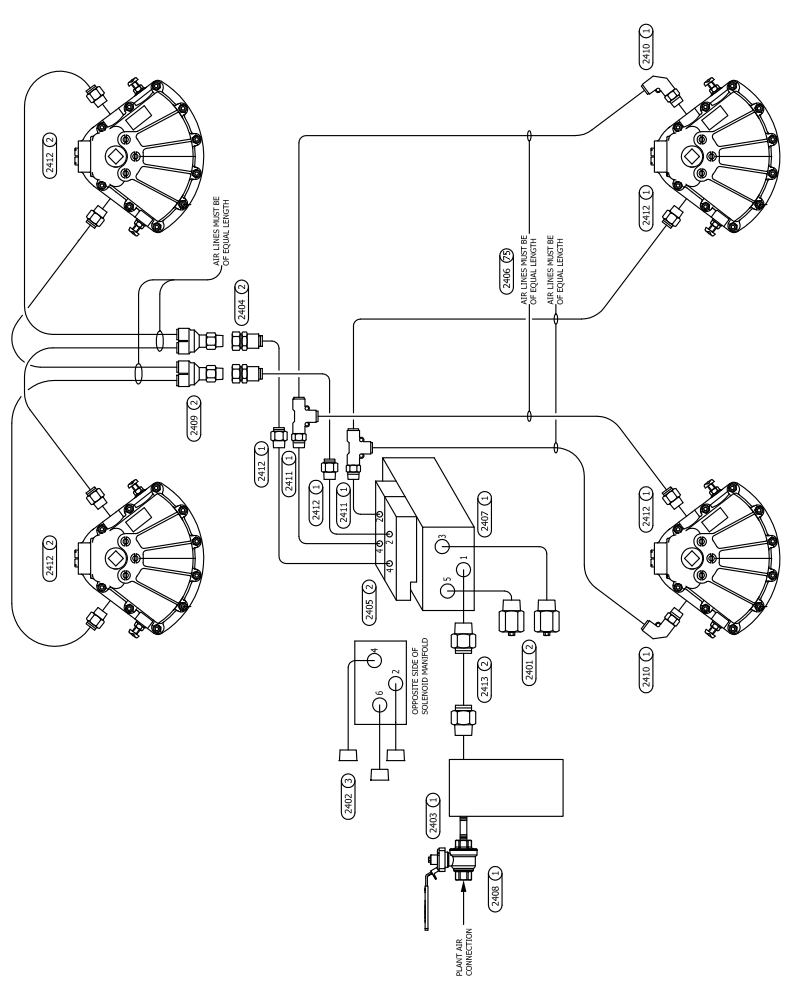

FOR CONSTRUCTION

PRINTED: 3/12/2010

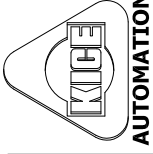

NOTES:
 CONTROL PULSE VISING: _____
 FIELD VIBRATING: _____
 P.A.O. = FURNISHED BY OTHERS

REV.	DATE	BY
1	2/26/10	DAG

JOB TITLE
KICE DUMP SCALE STANDARD (REV. 3)
 CUSTOMER NAME & LOCATION
 INDUSTRIES, INC.
 WICHITA, KS
 SITE NAME & LOCATION
 KICE INDUSTRIES, INC.
 WICHITA, KS

SCALE: _____ DRAWN BY: _____
 NOT TO SCALE: _____ MAF: _____
 DATE: 4/21/09 APPROVED BY: SA
 PLOT SCALE: 1.00 MINOR REVISION: 000
 SALES ORDER NO.: _____ STANDARDS: _____
 DWG TITLE: I/O CONNECTION SCHEMATIC
 DWG NO: 10-AA

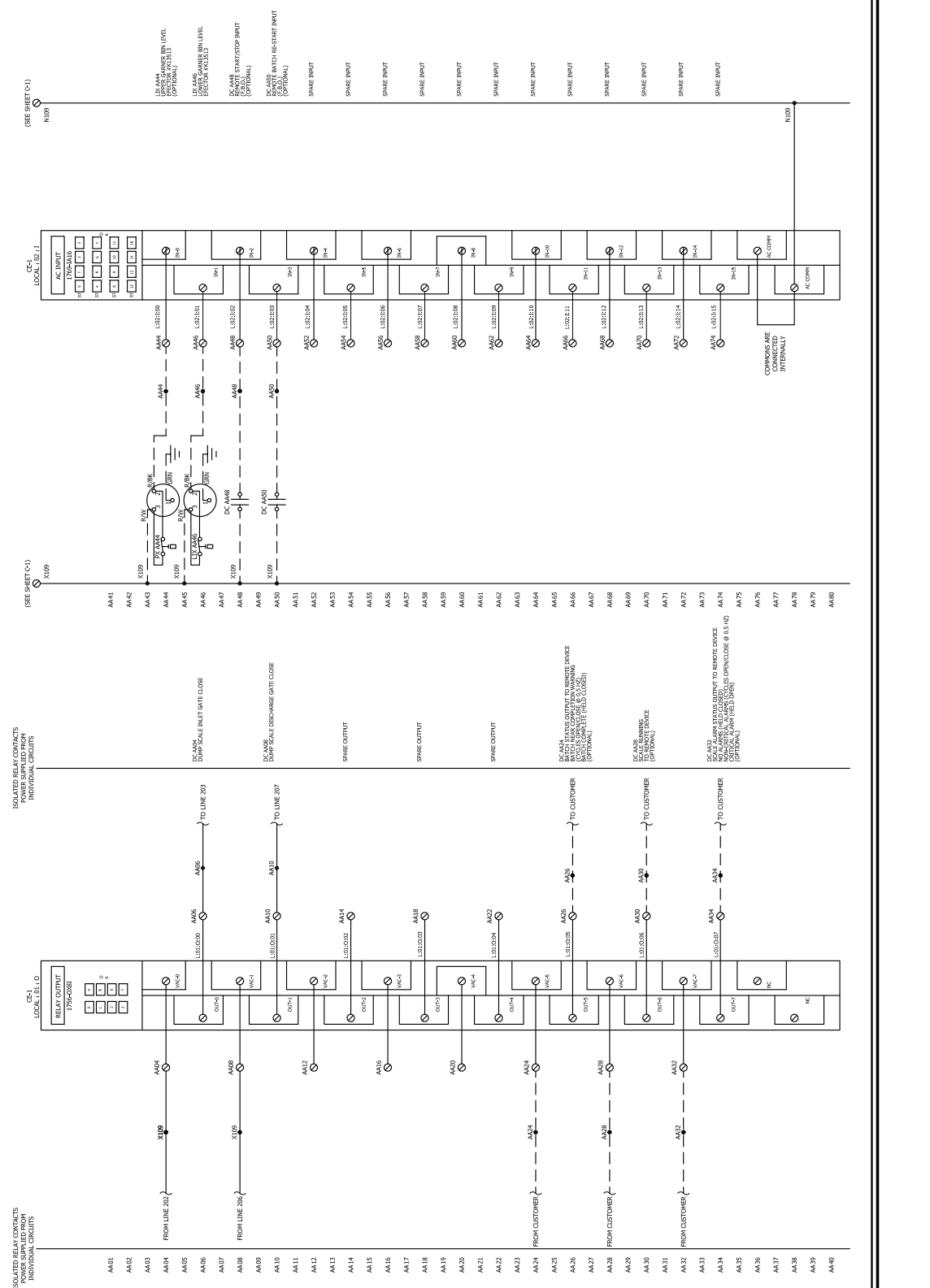

Kice Industries, Inc.
5500 Mill Heights Drive
Wichita, KS 67219



www.kice.com

P: 316-744-7151
F: 316-744-7355

SCL-Manual1