



KICE Industries

VL ROTARY AIRLOCK



OPERATOR'S MANUAL

CONGRATULATIONS...

When you purchased your new Kice Airlock, you bought a dependable and quality-built product. The series of airlocks manufactured by Kice, and the range of options and materials, should satisfy nearly every conceivable industrial airlock need.

We are proud of our products and the people at Kice who build them. At Kice, the manufacturing process starts in our own foundry by following the construction standards and manufacturing techniques that have proven superior over the last 60 years.

This owner's manual is intended as a guide for proper installation, operation and maintenance to keep your Kice airlock operating safely and efficiently on the job. Service and factory reconditioning information is also included for your benefit.

Sincerely,

Drew Kice
President
Kice Industries, Inc.

WARRANTY

The company warrants the equipment manufactured by the Company to be free of defects in material and workmanship for a period of one year from the date of shipment. Company agrees to repair or replace, at its option, any parts found to be defective in the opinion of the Company. Company is not liable for any costs in connection with the removal, shipment or reinstallation of said parts. This warranty does not apply to abrasion, corrosion, or erosion.

Purchaser agrees to look to the warranty, if any, of the manufacturer or supplier of equipment manufactured by others and supplied to the Company for any alleged defects in such equipment and for any damages or injuries caused thereby or as a result thereof. PURCHASER SHALL BE RESPONSIBLE FOR COMPLIANCE WITH ELECTRICAL MANUFACTURER'S RECOMMENDATIONS, UNDERWRITERS CODE AND ALL SAFETY PRECAUTIONS.

The only warranty extended under this agreement is the above express warranty and there are no other warranties, express or implied, including warranties of merchantability, fitness for a particular purpose or otherwise which extend beyond the face hereof. The Company and its dealers shall not in any event be liable for consequential or incidental damages and this agreement provides purchaser's sole and exclusive remedy. Any actions for breach of this agreement or warranty must be commenced within one year after the cause of action has occurred.

TABLE OF CONTENTS

1. GENERAL INFORMATION	4
2. SAFETY PRECAUTIONS	6
3. PRE-INSTALLATION PREPARATION	8
4. INSTALLATION	10
5. MAINTENANCE AND SERVICE	11
6. ILLUSTRATED PARTS LIST	15

IMPORTANT: WRITE DOWN THE MODEL AND SERIAL NUMBER OF YOUR AIRLOCK.

For additional information, application assistance or special service, you should contact your service representative or the factory. We will need to know the model and serial number of your airlock. For ready reference, please record them and the date of delivery or installation on the lines below. See the General Information section for the location of the model and serial number.

Model:

Serial Number:

Date of delivery or installation:

This manual applies to Kice Airlock Models VL.

1. GENERAL INFORMATION

TO THE OWNER

The purpose of this manual is to assist owners and operators in maintaining and operating the Kice airlock and attachments. Please read it carefully; information and instructions furnished can help you achieve years of dependable performance. A separate gearmotor manual should be included with your owner's packet. They contain additional information that may not be repeated in this manual. You are urged to read it before attempting any operation or repair of the gearmotor. If these manuals are not included in your owner's packet, contact our customer service department.

USING THIS MANUAL

General operation, adjustment and maintenance guidelines are outlined for owners and operators of Kice airlocks. Operating conditions vary considerably and cannot be addressed individually. Through experience, however, operators should have no difficulty in developing good operating, safety and monitoring skills.

The term "disconnect and lockout" as used in this manual means that power to the airlock has been disconnected through the use of a padlockable, manual, power cutoff, or power lockout switch.

Directions used in this manual, for example RIGHT or LEFT, CLOCKWISE or COUNTERCLOCKWISE, refer to directions when facing the end of the airlock that has the metal identification plate attached to it containing the model and serial number.

Photographs and illustrations were current at the time of printing, but subsequent production changes may cause your airlock to vary slightly in detail. Kice Industries, Inc., reserves the right to redesign and change the airlock as deemed necessary, without notification. If a change has been made to your airlock that is not reflected in this owner's manual or the Illustrated Parts Lists, write or call Kice Industries, Inc., for current information and parts.

MODEL AND SERIAL NUMBER

The airlock model and serial number can be found here:

Stamped on the metal identification plate located on the airlock end plate with the drive mechanism (see Figure 1).



Figure 1

FOR AIRLOCK PARTS AND SERVICE

Use original Kice airlock replacement parts only. These parts are available from Kice Industries, Inc., only. To obtain prompt, efficient service, always provide the following information when ordering parts:

1. Correct part description and number, as given in the Illustrated Parts Lists section of this manual.
2. Correct model number.
3. Correct serial number.

For assistance in service or ordering parts, contact the customer service department at:

Kice Industries, Inc.
5500 Mill Heights Drive
Wichita, KS 67219-2358
Phone: 316-744-7151
Fax: 316-744-7355.

IMPORTANT: Any unauthorized modification, alteration, or use of non-approved attachments or drive units voids the warranty and releases Kice Industries, Inc., from any liability arising from subsequent use of this equipment. Each type of airlock is designed to be used in specific situations, handling particular types of material. Using an airlock for any purpose other than that for which it was designed could result in personal injury, as well as, product or property damage.

FOR MOTOR AND SPEED REDUCER PARTS AND SERVICE

The gearmotor is covered by the manufacturer's warranty. If there is a problem, check with the local supplier or service representative.

2. SAFETY PRECAUTIONS



This safety alert symbol is used to call your attention to an important safety message on equipment, safety decals and in manuals, to warn you of possible danger to your personal safety. When you see this symbol, be alert; your personal safety or the safety of other persons is involved. Follow the instructions in the safety message.

The following definitions for identifying hazard levels are:



DANGER (RED) – Danger is used to indicate the presence of a hazard that WILL cause SEVERE personal injury, death, or substantial property damage if the warning is ignored.



WARNING (ORANGE) – Warning is used to indicate the presence of a hazard that CAN cause SEVERE personal injury, death, or substantial property damage if the warning is ignored.



CAUTION (YELLOW) – Caution is used to indicate the presence of a hazard that WILL or CAN cause MINOR personal injury or property damage if the warning is ignored.



WARNING: All owners and operators should read this manual, or be instructed in safe operating and maintenance procedures, before attempting to uncrate, install, operate, adjust, or service this equipment.

SAFETY DECALS

The airlock safety decals should not be removed, covered over, painted, or otherwise become illegible. If this occurs, they should be replaced immediately. Contact our customer service department for replacements.

The following safety decals will be located on the airlock body, chain guard or motor. Look for them!



SAFETY PRECAUTIONS CONTINUED

ADDITIONAL SAFETY PRECAUTIONS:

- Do not attempt to install, connect power to, operate or service an airlock without proper instruction and until you have been thoroughly trained in its use by your employer.
- Do not manually override or electrically bypass any protective device.
- Do not connect power to or operate an airlock unless all moving parts are covered and all covers, guards, grates, and maintenance panels are in place and securely fastened.
- Do not abuse, overload, mistreat or misuse an airlock or attempt to operate it if it is in need of service, lubrication, maintenance or repair. Do not attempt to start an airlock when loaded.
- Never place any part of your body under or near rotating members or moving parts of an airlock.
- If an airlock is not equipped with a factory supplied chain guard, rotating members and moving parts must be completely enclosed before connecting power and before operation.
- If an airlock is equipped with a maintenance panel incorporating any Protective Interlocking Limit Switch (PLS), the PLS must be interlocked with all electrical controls so that all motors or powered devices on the unit will be de-energized if any protected cover, guard, grate or maintenance panel is open or removed. Never attempt to manually override or electrically bypass the PLS safety device. The interlock function of the PLS must be tested and logged daily by supervisory personnel.
- Many airlocks are installed and wired to start automatically or be controlled from remote locations. Keep away from such airlocks at all times.
- An airlock must be equipped with a properly functioning Protective Interlocking Electrical Control Switch (PCS), a Padlockable Manual Power Lockout Switch, and with the other basic safety equipment listed above. On-off, interlock and padlock functions of the PCS must be tested and logged daily by supervisory personnel.
- It is the owner's and the employer's responsibility to adequately train the employee-operator in the proper and safe use of airlocks. Written safety programs and formal instruction are essential. All new employees must be made aware of company policies and operating rules, especially the established safety and health procedures. Refresher training of experienced employees in the potential hazards of the job is important. Up-to-date training records must be maintained at the job site.
- Special attention must be devoted to outside contractors engaged to enter and perform work on an airlock or in the workplace. Special care must be exercised to insure all such personnel are fully informed of the potential hazards and follow plant rules – with special emphasis on explosion proof electrical tools and cutting or welding in unsafe environments.
- Keep the workplace clean and free of dirt and dust at all times. Do not attempt to work on slippery or unsafe ladders or work platforms when maintenance or repair work is being performed on an airlock.
- Do not climb on ladders or work on platforms unless maximum load rating is posted. Do not exceed maximum load ratings when installing or servicing an airlock.
- Never allow any kind of metal or other foreign objects to enter an airlock.
- All airlock inlet and discharge openings must be completely enclosed to prevent human access when airlock is operating, and must remain enclosed until POWER IS TURNED OFF AND LOCKED OUT. Keep away from an airlock when it is running.
- Operate safely at all times. Use personal protective equipment when and where appropriate, such as hard hats, helmets, gloves, earplugs, and eye protection devices. Keep personal protective equipment in good repair and convenient to the operator.
- Drive components must be inspected and adjusted after transportation and periodically as required by operating conditions. Check sprocket and coupling alignment and spacing, chain tension, setscrews, keys and other fasteners, bearings, shafts, gear reducers and motors, as appropriate to job conditions.
- High voltage and rotating parts can cause serious or fatal injury. Only qualified, trained, and experienced personnel should perform installation, operation and maintenance of electrical machinery. Make sure that the motor and the frame of each airlock is effectively grounded in accordance with OSHA safety and health standards, the National Electrical Code and local codes.
- Never stand under any kind of hoist or lifting mechanism, whether or not it is loaded or in operation. Never stand under or near an airlock or component when it is being lifted.
- All airlock lifting devices must be carefully inspected by qualified personnel before each use. Never use a lifting device to transport an airlock. Never use a lifting device that is damaged, deteriorated, or in any way in need of repair.
- All protective covers, guards, grates, maintenance panels, switches and warning decals must be kept in place and in good repair. Any airlock with a damaged, malfunctioning, defective, or missing protective device must be taken out of service until the protective device can be repaired or replaced.
- Any device powered by air or hydraulic pressure must be equipped with a properly functioning Padlockable Manual Pressure Lockout and Internal Pressure Relief Valve (PLV).
- Any airlock that is used in the processing of explosive materials in hazardous environments requires an evaluation on the part of the user and operator of proper and adequate airlock monitoring equipment, dust control, explosion relief venting, and electrical equipment enclosures. Do not use your airlock in hazardous environments unless it has been properly equipped for the hazard.
- It is ultimately the operator's responsibility to implement the above listed precautions and insure proper airlock use, maintenance and lubrication. Keep these instructions and list of warnings with your machine at all times.

WORK SAFELY AT ALL TIMES

- Do not attempt to work on, clean or service an airlock, or open or remove any protective cover, guard, grate or maintenance panel until the POWER has been turned off and LOCKED OUT, and the airlock has come to a complete stop. Please ensure all the local, state, and OSHA laws are followed.
- All electrical or electronic maintenance and service should be performed only by trained and authorized technicians.
- Assume at all times that power is "on." Treat all conditions as live. This practice ensures a cautious approach that may prevent an accident or injury.
- Before applying power to any equipment, make certain that all personnel are clear of the machine.
- Compliance with the lockout/tagout standard (29 CFR 1910.147): This standard covers the servicing and maintenance of machines and equipment in which the unexpected energization or startup of the machines or equipment, or release of stored energy could cause injury to employees. This standard establishes minimum performance requirements for the control of such hazardous energy.

3. PRE-INSTALLATION PREPARATION

INSPECTING AND UNCRATING AFTER DELIVERY

1. Inspect the airlock shaft while the airlock is still secured to the shipping pallet.

- **To inspect the airlock shaft:**

- A. Remove the shaft cover located on the non-drive end of the shaft and the chain guard (see Figure 2).

- B. Check both ends of the shaft to see if they have been bent or damaged. If this is the case, file a claim with the freight company for damages and contact our customer service department.

- C. Replace the shaft cover and the chain guard.

- D. Be sure that the cover is firmly in place.



CAUTION: The shaft cover must be in place at all times. If the cover is lost in shipment or lost during airlock operation, contact our customer service department for a replacement at no charge.

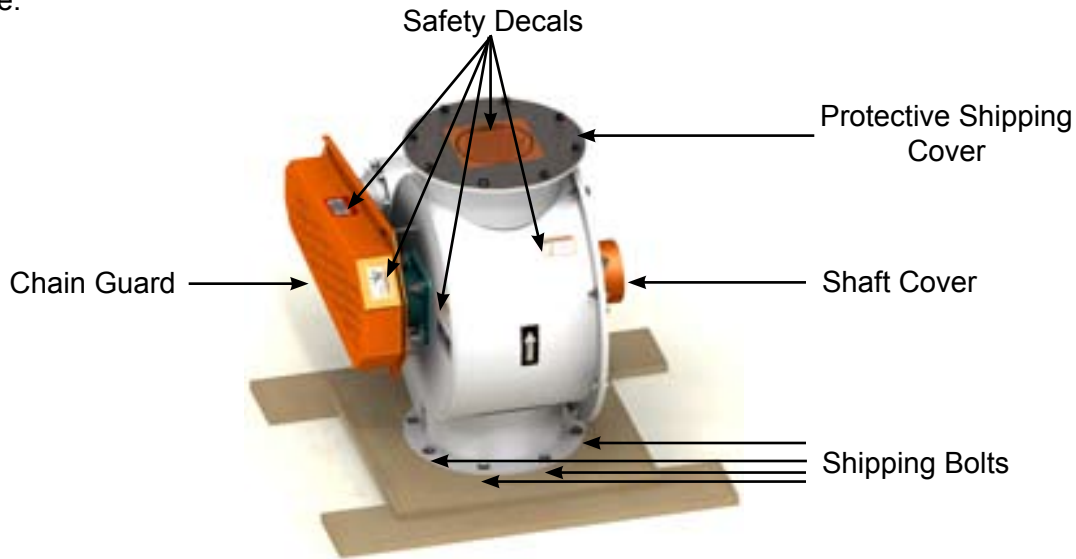

Figure 2

2. Remove the airlock from the shipping pallet.

- **Uncrate the airlock in the following manner:**

- A. Remove the shipping bolts securing the airlock to the shipping pallet (see Figure 2).

- B. Lift the airlock from the pallet using a tool truck or forklift.

- C. Set the airlock on a smooth level surface.

- D. Verify all bolts are installed securely.

3. Inspect the rotor.

- **To inspect the rotor:**

- A. Locate and read all safety decals (see Figure 2).

- B. Remove the protective shipping cover (see Figure 2).



CAUTION: When the protective shipping cover is removed from the airlock, do not place hands in the airlock or attempt to turn the rotor by hand. Personal injury could occur.

PRE INSTALLATION PREPARATION CONTINUED

C. Using a soft probe, check the rotor and the interior of the airlock for foreign material.

- **For airlocks with the drive motor attached:**

D. Connect the airlock motor to the power source to verify rotation. Disconnect and lockout power then connect chain. Connect airlock motor to power source. If the rotor turns freely, disconnect the power source; and remove chain to prepare for installation.



DANGER: Do not place hands or feet in the airlock while the power source is connected to the motor.



WARNING: Always wear proper eye protection.

E. If the rotor does not turn freely refer to Maintenance and Service (section 5 of this manual) for proper procedures.



CAUTION: If the motor or speed reducer produces an unusual noise, disconnect the power and lockout. Then check rotation to be sure motor is not wired backwards.

4. Inspect the motor.

- **Inspect the airlock motor in the following manner:**

- A. Read all the materials supplied with the airlock concerning the motor.
- B. Be sure that the motor is securely mounted to the airlock.

5. Inspect the speed reducer.

- **Inspect the speed reducer in the following manner:**

- A. Read all the materials supplied with the airlock concerning the speed reducer.
- B. Determine whether the speed reducer is grease lubricated (Kice standard) or oil lubricated.
- C. If the reducer is grease lubricated, do nothing. It has been filled with grease at the factory and is ready for use.
- D. If the reducer is oil lubricated, add the appropriate oil as specified by the manufacturer.

4. INSTALLATION



CAUTION: Use proper equipment when lifting or moving the airlock. Make sure all persons and obstructions are clear from path and installation area.

After uncrating and inspection has been completed, install the airlock in the following manner:

1. Move the airlock to the installation area using proper equipment.
2. Check the mounting surfaces of the airlock and any adjoining system components. They should be free of foreign materials.
3. Mount the airlock in place.
 - a. If the airlock is a floor-mounted model, secure to the floor using lag bolts or approved anchors and then attach the airlock mounting flange(s) to the system flange(s) using fasteners and the supplied gasket(s) (see Figure 3). Be certain that a gasket is installed between the airlock flange(s) and the system flange(s).



Figure 3

b. If the airlock is mounted into a system, but is not floor mounted, attach the airlock flange(s) to the system flange(s) using fasteners and the supplied gasket(s) (see Figure 3). The airlock should be attached to the sturdiest element first. Be certain that a gasket is installed between the airlock flange(s) and the system flange(s).

4. Tighten all mounting fasteners securely.



WARNING: High voltage and rotating parts can cause serious or fatal injury. Only qualified, trained, and experienced personnel should perform installation, operation and maintenance of electrical machinery. Make sure that the motor and the frame of the airlock is effectively grounded in accordance with OSHA safety and health standards, the National Electrical Code, and local codes.

5. Connect the power source to the airlock motor.



WARNING: Verify rotation, failure to verify rotation prior to connecting chain may result in damage to the drive chain.

6. Verify rotation. If the gearmotor output was turning in the wrong direction, reverse wiring leads to motor and retest.
7. Disconnect and lockout power.
8. Connect chain.
9. Connect the power source to the airlock motor.

5. MAINTENANCE AND SERVICE

The key to long and trouble-free airlock operation is good maintenance practices. Periodically inspect the rotor for damage caused by foreign material and for proper placement within the airlock body. Inspect the bearings and the drive chain for excessive wear. Finally, service the gearmotor as specified by the manufacturer.

The majority of operating problems that occur with an airlock can be traced to improper adjustments and delayed, or neglected, maintenance. A consistently applied maintenance program will prevent many problems.

A thorough understanding of the system is a must if the operating problems are to be corrected satisfactorily. A good rule to follow when troubleshooting a problem is to never make more than one adjustment at a time, thereby isolating the problem by a process of elimination. The cause of a problem is usually simple and is easy to pinpoint if you systematically check each system and function.

DRIVE CHAIN MAINTENANCE

- After approximately 48 hours of initial operation, check the drive chain tension. Check it again in 2 to 3 weeks. The following procedures should be followed if the drive chain needs adjusting or replacing.



CAUTION: The airlock drive uses a self-lubricated chain. Do not oil or otherwise lubricate.

DRIVE CHAIN TENSION

- When pressed down midway between the sprockets, the drive chain should have a deflection of 2% - 3% of the shaft center distance under no load. (Example: 20" shaft center to center distance, deflection will be about 1/2").
- Adjust the drive tension in the following manner:
 1. Disconnect and lock out power.
 2. Remove the chain guard.
 3. Loosen the mounting bolts.

NOTE: If the drive chain is to be replaced, remove it at this time by removing the connecting link and install a new drive chain. Then proceed with the remaining procedures.

4. Tighten the drive chain by turning the jack bolts clockwise.
5. When proper chain tension is achieved, retighten the mounting bolts.
6. Reinstall the chain guard.
7. Reconnect power.

MAINTENANCE AND SERVICE CONTINUED

DRIVE CHAIN SPROCKETS

If a sprocket becomes worn, it will need to be replaced.

• **To replace:**

1. Disconnect and lock out power.
2. Remove the chain guard.
3. Remove the drive chain (see above procedure).
4. Loosen sprocket setscrews.
5. Remove the sprocket.
6. Remove the sprocket by slipping it off the shaft.
7. Install a new sprocket onto the airlock shaft.
8. Align the driver sprocket on the speed reducer shaft with the driven sprocket on the airlock shaft.
9. Reinstall the drive chain.
10. Reinstall the chain guard.
11. Reconnect power.



GEARMOTOR

1. Disconnect and lockout power.
2. Remove chain guard.
3. Remove chain.
4. Remove chain guard backplate.
5. Disconnect electrical wiring from gearmotor.
6. Remove gearmotor from gearmotor mount slide.
7. Remove sprocket.
8. To install, follow above steps in reverse order being sure to verify rotation prior to connecting chain.

GEARMOTOR SERVICE

To obtain parts or service for the airlock gearmotor, contact the local dealer or service representative for the particular make of gearmotor used on the airlock. Not all airlocks use the same make. The manufacturer has supplied you with safety, service, and repair information. If you have difficulty obtaining service or repair parts, contact our customer service department.

MAINTENANCE AND SERVICE CONTINUED

BEARINGS

When replacing bearings, use Kice replacement parts from parts page.

- To remove bearings:
 1. Follow SOP lockout/tagout procedures.
 2. Scribe horizontal and vertical reference marks along wiper cover plate and onto housing or mark bearing position on shaft using a permanent marker.
 3. Remove chain guard cover.
 4. Remove chain.
 5. Remove sprockets.
 6. Remove chain guard backplate.
 7. Loosen bearing eccentric lock collar.
 8. Unbolt bearing.
 9. Remove shaft seal (parts page) - Kice recommends replacing the shaft seal while it is readily accessible.
 10. To replace or install bearings, follow the above steps in reverse order.

SHAFT SEAL

- To remove shaft seals:
 1. Follow steps to remove bearings.
 2. Remove shaft seal.
 3. To replace or install seals, follow the above steps in reverse order.



WARNING: Never place hands or fingers in an airlock, unless it has been disconnected and locked out, and a wooden block has been placed in the airlock to prevent the rotor from turning.

ROTOR

If the rotor becomes blocked, or does not turn freely:

- **First**
 4. Disconnect and lockout power.
 5. Gain access to the rotor.
 6. Place a block in the airlock to prevent the rotor from turning.
- **Then, for blockage in rotor**
 7. Using a probe, dislodge the obstruction from the rotor and discard (See Figure 8).
 8. Inspect for additional foreign material.
- **For rotor damage – rotor does not turn freely**
 9. Remove rotor from housing.
 10. Remove wipers from rotor.
 11. Repair rotor weldment if required.
 12. Replace wipers with new (parts section).

MAINTENANCE AND SERVICE CONTINUED

13. If beyond repair order new rotor (parts section).

- **To remove the rotor:**

1. Disconnect and lock out power.
2. Scribe horizontal and vertical reference marks along wiper cover plate and onto housing or mark bearing position on shaft using a permanent marker.
3. Remove the chain guard and shaft cover.
4. Remove the drive chain.
5. Remove the sprockets and bushing and the chain guard backplate.
6. Remove both lock collars and dress the shaft using a file and emery cloth.



CAUTION: Burrs or dents must be removed from the rotor shaft before attempting bearing removal to prevent scoring of inner race.

7. Remove the bolts on plate (see Figure 4).
8. Tap on the rotor shaft using a soft hammer
9. Remove the end plate (see Figure 4).
10. Remove the rotor by pulling it out of the airlock body.
11. To replace or reinstall the rotor, follow the above steps in reverse order. Ensure wipers are deflected in correct direction when placing rotor in housing.



Figure 4

WIPERS

- To remove wipers:

1. Follow rotor removal instructions.
2. Unbolt wiper cover plates and remove bolts (parts page).
3. Using new bolts align wipers with wiper cover plates.
4. Fasten with new lock nuts.
5. Complete installation by following rotor removal steps in reverse.

6. ILLUSTRATED PARTS LIST

Part	Airlock Size	Part Number	Picture
Bearing	VL18x10	10000984	
	VL23x12	10000984	
	VL26x14	10000985	
	VL30x16	10000985	
	VL36x20	10000986	
	VL40x24	10000986	
Connection Flange Gasket	VL18x10	GSKTA10RD.0625B	
	VL23x12	GSKTA12RD.0625B	
	VL26x14	GSKTA14RD.0625B	
	VL30x16	GSKTVLA163/16RD.0625BNW	
	VL36x20	GSKTVLA203/16RD.0625BNW	
	VL40x24	GSKTVLA243/16RD.0625BNW	
Gearmotor	VL18x10	10001203	
	VL23x12	10001204	
	VL26x14	10001204	
	VL30x16	10001204	
	VL36x20	10001205	
	VL40x24	10001205	
Rotor	VL18x10	RAV-610-2200	
	VL23x12	RAV-612-2200	
	VL26x14	RAV-614-2200	
	VL30x16	RAV-616-2200	
	VL36x20	RAV-620-2200	
	VL40x24	RAV-624-2200	
Sprockets	VL18x10 DriveR / DriveN	50BS15HT1 1/8 - 50BS36T1 3/4	
	VL23x12 DriveR / DriveN	60BS15HT 1 1/2 - 60BS36T2	
	VL26x14 DriveR / DriveN	60BS15HT1 1/2 - 60BS36T2	
	VL30x16 DriveR / DriveN	60BS15HT1 1/2 - 60BS44T2	
	VL36x20 DriveR / DriveN	80BS16HT1 1/2 - 80-SF-45T & SF 2 1/4	
	VL40x24 DriveR / DriveN	80BS16HT1 1/2 - 80-SF-45T & SF2 1/4	
Shaft Seal	VL18x10	RAV-600-3001	
	VL23x12	RAV-600-3002	
	VL26x14	RAV-600-3002	
	VL30x16	RAV-600-3002	
	VL36x20	RAV-600-3003	
	VL40x24	RAV-600-3003	
Wiper Cover Plate	VL18x10	RAV-610-3204	
	VL23x12	RAV-612-3204	
	VL26x14	RAV-614-3204	
	VL30x16	RAV-616-3204	
	VL36x20	RAV-620-3204	
	VL40x24	RAV-624-3204	
Wiper (8 per airlock)	VL18x10	RAV-610-3203	
	VL23x12	RAV-612-3203	
	VL26x14	RAV-614-3203	
	VL30x16	RAV-616-3203	
	VL36x20	RAV-620-3203	
	VL40x24	RAV-624-3203	

BILL OF MATERIAL	
ITEM	DESCRIPTION
1	HOUSING (WM)
2	ROTOR ASSEMBLY
3	(1) - ROTOR (WM)
4	(8) - ROTOR WIPER
5	(8) - ROTOR WIPER COVER PLATE
6	REMOVABLE SIDE PLATE
7	SHAFT SEAL
8	BEARING
9	MOTOR MOUNT SLIDE
10	GEARMOTOR
11	DR SPROCKET
12	DN SPROCKET
13	CHAIN GUARD BACK PLATE
14	CHAIN GUARD SLIDING PLATE
15	CHAIN GUARD COVER
16	SHAFT GUARD

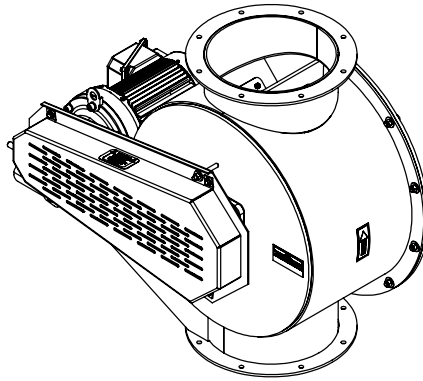

ISOMETRIC REFERENCE VIEW

BILL OF MATERIAL	
ITEM	DESCRIPTION
17	ROTATION ARROW DECAL
18	NAMEPLATE
19	WARNING, FAILURE TO VERIFY
20	HEX CAP SCREW, 1/4-20 x 1/2" LG
21	HEX CAP SCREW, 1/4-20 x 1 1/4" LG
22	FLAT WASHER, 1/4
23	HEX NUT, 1/4-20, NYLOCK
24	HEX CAP SCREW, 3/8-16 x 1 1/4" LG
25	HEX NUT, 3/8-16
26	FLAT WASHER, 3/8
27	HEX CAP SCREW, 1/2-13 x 1 3/4" LG
28	FLAT WASHER, 1/2
29	HEX NUT, 1/2-13
30	FLAT WASHER, 5/8
31	LOCK WASHER, 5/8
32	HEX NUT, 5/8-11

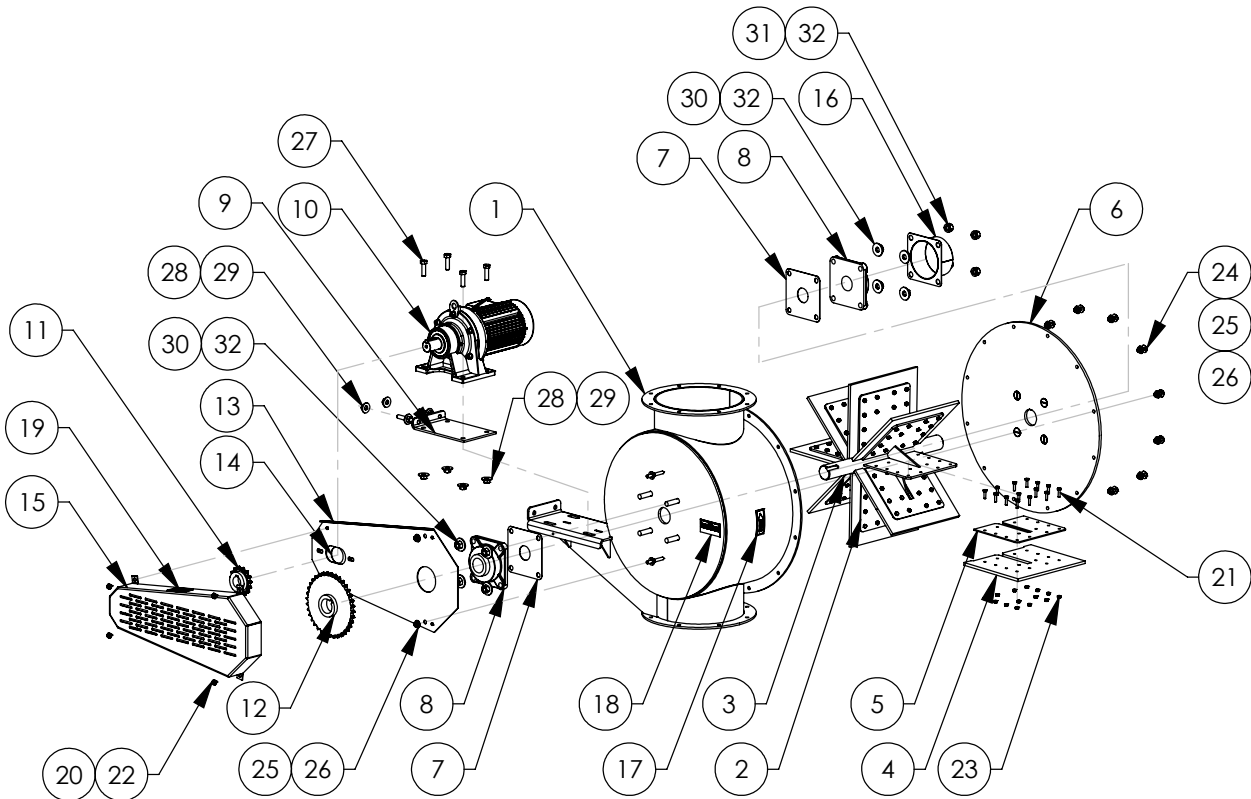

VL AIRLOCK

DESCRIPTION:



KICE INDUSTRIES, INC.

5500 MILL HEIGHTS DR. WICHITA, KANSAS 67219
 PH: (316) 744-7151 FAX: (316) 744-7355

JBS

DWN:

12-15-09

DATE:

RAV-5006

DWG. NO.

Kice Industries, Inc.
5500 Mill Heights Drive
Wichita, KS 67219



www.kice.com

P: 316-744-7151
F: 316-744-7355