



# IFS INTAKE FILTER/SILENCER

SIZE 4 AND UNDER

KICE INDUSTRIES, INC. / 5500 Mill Heights Drive / Park City, KS 67219    www.kice.com / sales@kice.com

IFS ASSEMBLY CONSISTS OF SIX BASIC PARTS:

- 1) BASE UNIT
- 2) EXPANDED WIRE CAGE WITH STEEL CAP
- 3) FILTER - OPEN CELL POLYURETHANE FOAM MEDIA 2 PLY - COARSE AND FINE. TO PROVIDE DEPTH LOADING FOR DUST HOLDING CAPACITY
- 4) SOUND ABSORBING FOAM / BARRIER
- 5) SHELL - THERMOFORMED ORANGE DOME LINED WITH SOUND ABSORBING FOAM BARRIER
- 6) CONNECTION - NPT THREADED PIPE - FLANGE ADAPTER
- 7) REPLACEMENT FILTER ELEMENT P/N:  
- 1-1156-03

CLEANING - EASILY CLEANED BY ONE OF THE FOLLOWING METHODS:

- 1) SHAKING OR BEATING
- 2) BLOWING WITH COMPRESSED AIR
- 3) WASHING WITH WARM WATER AND DETERGENT. DOES NOT SHRINK. AIR DRY ONLY
- 4) NO OILING REQUIRED

MODEL #	PIPE SIZE	A	B	C
IFS 2	2	8	22 3/16	20
IFS 2 1/2	6	12	22 3/16	20
IFS 3	3	8	22 3/16	20
IFS 4	4	8	22 3/16	20

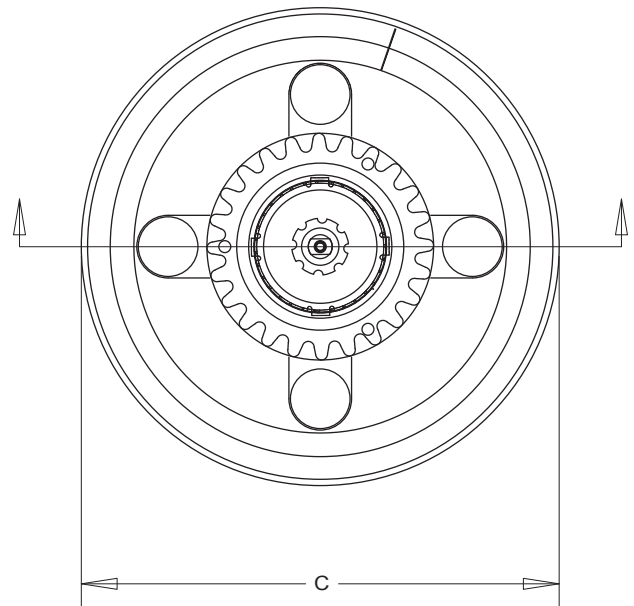

TOP VIEW

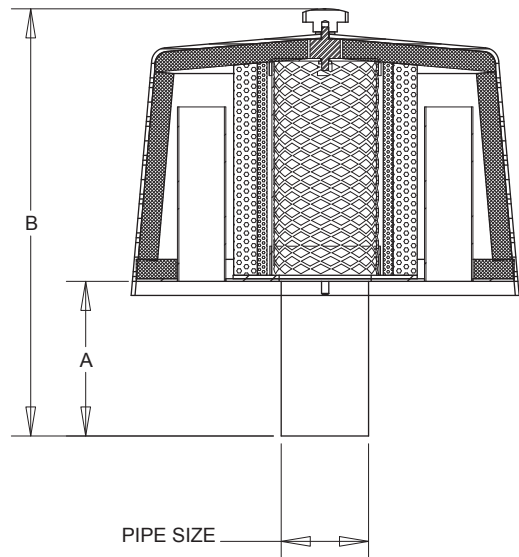

SIDE VIEW

IFS INTAKE FILTER/SILENCER

DWG. NO.  
APU-1004